



Radiocommunications Agency
Ministry of Economic Affairs

Analysis

of interference to cable television
due to mobile usage in the
Digital Dividend



UNIVERSITY OF TWENTE.

Colophon

© 2010 Radiocommunications Agency Netherlands

ISBN 978 908 15 7322 1

Commissioned by
Ministry of Economic Affairs

Conducted by
Radiocommunications Agency Netherlands in
cooperation with University of Twente

Contact details
Radiocommunications Agency Netherlands
PO Box 450
9700 AL Groningen
+31 (0)50 58 77 444
www.agentschap-telecom.nl
agentschaptelecom@at-ez.nl

Publication date
July 2010



Radiocommunications Agency
Ministry of Economic Affairs

Analysis

of interference to cable television
due to mobile usage in the
Digital Dividend

UNIVERSITY OF TWENTE.

This Report was created in cooperation
with the University of Twente.

Content

Summary	6
1 Introduction	10
2 Calculation of statistical probability of interference	13
2.1 Introduction	14
2.2 Basic co-channelling principles	14
2.3 Different scenarios for the probability of co-channeling	15
2.4 Translation of interference probability to real-life situation	17
2.4.1 Scenario I: how many households will experience interference?	18
2.4.2 Scenario II: how many households will experience interference?	19
2.4.3 Influence of behaviour of LTE handset users on the interference figures	20
2.5 What do these probabilities mean for cable companies?	21
3 Technical study of interference if co-channeling occurs	22
3.1 Introduction	23
3.2 Approach to and method of study	23
3.3 Results of simulation	24
3.4 Description of process	25
4 Measures	26
4.1 Introduction	27
4.2 Measures that consumers can take	27
4.3 Costs of measures	27
4.4 Effectiveness of measures	28
4.5 Measures that other parties can take	28
5 Foreign studies and policy	29
5.1 Introduction	30
5.2 Foreign studies	30
5.3 Policy and approach in other countries	31
6 Conclusion	32
List of Annexes	35

Summary

The start of use of mobile applications in the 800 MHz band, which forms part of the ‘Digital Dividend’, will cause interference to TV signals under certain conditions. The new mobile applications (called LTE, Long Term Evolution) use frequencies also used in cable TV networks. This report examines how much interference may occur when providing digital television over cable networks.¹

¹ The cable signals do not cause interference to the mobile handset.

An initial exploratory study carried out by Agentschap Telecom (Radiocommunications Agency Netherlands, 'the Agency') in November 2009² revealed that there was an approximately 75% probability that LTE mobile applications would interfere with digital cable TV.

This probability of interference occurs under worst-case conditions where the cable TV receiver and LTE mobile device are both using the same frequency (called co-channelling). A supplementary study was necessary to identify the likely scale of interference and, in particular, ways of solving it. This report presents the results of the supplementary study.

The Agency carried out the study in cooperation with the University of Twente. The two organisations each performed some of the measurements and reported their results. The Agency further examined the seriousness of the problem while the University looked at ways of tackling it. There was a mutual verification of results.

This study adjusts some of the assumptions made in the original study conducted in 2009, and the statistical probability of co-channelling (i.e. the condition necessary for interference) now forms an integral part of the study.

Two main probabilities were examined to identify the probability and degree of interference. Firstly, there is the probability of a person making a phone call on the same channel as the one to which the TV is tuned at that particular moment in time. Secondly, there is the probability that, given the existence of co-channelling, this will actually disturb the digital TV signal.

The main assumptions and findings of the study were:

- 1 The study examined interference to the *digital* relay of TV signals in the cable offering. The probability of interference to analogue TV signals is almost 100%, given the existence of co-channelling. It was assumed that at the time of widespread introduction of LTE, the use of analogue cable TV in these frequency bands will have been phased out almost completely.
- 2 Interference may occur to a watched television programme only if an 800 MHz mobile handset transmits at a certain moment on the same channel as the one on which the television programme is being relayed *at that particular moment*.

- 3 The potential interference to TV channels adjacent to the four channels subject to direct interference by LTE was not factored in, because this interference does not significantly increase the total interference probability.
- 4 Therefore, interference is possible only if a mobile handset is active in the 800 MHz spectrum that is also being used to distribute television programmes by cable.³
- 5 The probability of coincidence of mobile LTE channels and TV channels at the same moment (co-channelling) is 0.35%, assuming that the television programmes are distributed arbitrarily across the TV frequency band.
 - if the 30 most frequently viewed TV stations are not programmed in the LTE channels, this probability will be 0.035%.
- 6 Not every instance of co-channelling leads to interference. On average, in 48% of all instances where this situation occurs, interference will be caused to the TV programme being viewed at that particular moment.
- 7 This 48% probability of interference, if there is co-channelling, may be higher or lower for an individual consumer, depending on the specific situation at the consumer's home.
 - if the consumer uses good quality cables and, in particular, good plugs in the home, this percentage will be lower by roughly half;
 - if a consumer lives relatively far away from a base station, this percentage will be higher. This is because the mobile handset must generate more power to contact the base station;
 - if the 800 MHz mobile handset is relatively far away from the weakest point of the cable and/or from the place in the living room where the set-top box (or digital TV that works without a set-top box) is located, the probability of interference will be lower than when the mobile handset is near these radiation points.

For an individual consumer, a combination of these three factors will result in a higher or lower probability of interference, given the existence of co-channelling at the consumer's premises at that moment.

- 8 The calculated probabilities assume that interference will initially be caused by the use of a person's own 800 MHz LTE mobile handset within the home. However, the interference may also originate from a neighbour's or passer-

² Agentschap Telecom, *Study of interference to digital cable TV caused by 800 MHz mobile LTE applications; Report on 1st and 2nd sets of tests*, Report for DGET, Groningen, 27 November 2009.

³ The LTE base stations can also cause interference in principle. Despite the greater power this is negligible because of the far greater distances in comparison with the probability of interference caused by mobile handsets.

by's 800 MHz LTE mobile handset. If these influences are factored into the ultimate interference probability, the probabilities mentioned in findings 9 to 12 must be approximately doubled to let these external influences play a role.

- 9 From the foregoing it follows that the probability of a digital TV programme experiencing interference in an arbitrary household at the moment that an 800 MHz-suitable LTE mobile handset is being used in the household is 0.17%. This is the product of the two main probabilities: 0.35% x 48%. If this interference occurs, it will be sustained during use of the mobile handset at that moment:
 - if the 30 most frequently viewed television stations are not programmed in the LTE channels, this probability will be lower by roughly a factor of 10, namely 0.017%;
 - it should be noted that the stated probabilities apply *each time* a call is set up with a mobile handset where the 800 MHz spectrum is active and the TV is on at the same time.
- 10 To obtain an impression of the nature and scale of the problem, it was calculated, subject to certain assumptions, that:
 - this kind of interference will occur at approximately 5,000 households in the Netherlands on an average TV viewing evening.
 - in the scenario where the 30 most frequently viewed TV stations are not programmed in the LTE channels, 500 households will be affected by this kind of interference on an average TV viewing evening.
 - at an arbitrary *time* in the evening, this kind of interference will occur at the moment simultaneously at approximately 500 households throughout the Netherlands.
 - in the scenario where the 30 most frequently viewed TV stations are not programmed in the LTE channels, the number of affected households will be 50.
 - an arbitrary household that owns an LTE handset may experience this kind of interference approximately 7 times each year, for the duration of use of the LTE handset at that moment. The duration of interference depends greatly on the degree of mobile use during TV viewing.
 - in the scenario where the 30 most frequently viewed TV stations are not programmed in the LTE channels, this will occur less than once per year on average.
- 11 For cable companies, the numbers stated at item 10 may be an indicator of the dissatisfaction of customers with this interference and, as a consequence, a potential indicator of the likely number of complaints.
- 12 The probability of a person who is watching a TV station *programmed in the LTE band* experiencing interference is 2.5%. This is roughly 15 times higher than the general interference probability of 0.17%. This difference occurs because we are calculating here with a conditional probability, *given that a person is watching a TV station programmed in a potentially interference-sensitive TV channel*. The probability of interference will then naturally be higher.
 - If 1000 households are watching a TV station programmed in a digital TV channel that lies in the LTE band, roughly 25 of the households will experience interference to that station on an average TV evening, for the duration of use of the mobile handset at that moment.
- 13 What can an individual consumer do to reduce the probability of interference? A consumer can consider a number of measures to avoid this kind of interference:
 - replace in-home cables and especially plugs by ones with sufficient immunity. This will resolve the problem completely for approximately half of these consumers;
 - if future set-top boxes and digital television sets also have sufficient immunity, the problem will be resolved almost completely, in combination with the measure stated above.

It is difficult to estimate how many consumers will take these measures. Given the nature of the interference (occurring under certain conditions, temporarily and often caused by a person's own use of an LTE handset), it is not inconceivable that a large proportion of consumers will fail to realise that a problem exists that is resolvable by taking some measures.

- 14 What can other stakeholders do to reduce the probability of interference?
- cable companies could endeavour to avoid mobile LTE channels as far as possible when planning their cable offerings. If the most frequently viewed normal stations are *not* programmed on these frequencies (4 channels), the probability of co-channelling and by consequence interference will be reduced roughly by a factor of 10;
 - in due course the industry must ensure the marketing of televisions and set-top boxes that are sufficiently immune to inward radiation of 800 MHz frequencies. At present the industry is working in CENELEC and ETSI to establish new standards with sufficient immunity for the future;
 - through the planning of their networks, the mobile operators could endeavour to reduce the power generated by mobile handsets. The investment required to increase the density of the network can be as much as 300% of the original investment in the network.

The following conclusions may be drawn:

- The probability of a household being confronted by this kind of interference due to use of an 800 MHz-suitable LTE mobile handset is 0.17%, assuming that the digital television stations are distributed arbitrarily across the TV frequency band. So in 99.83% of all cases, this will not interfere with the signal of the viewed TV station.
 - if the 30 most frequently watched TV stations are not programmed in LTE channels, the interference probability will be 0.017%.
- Given the nature of the interference (occurring under specific conditions and usually due to use of a person's own LTE handset), there appears to be no reason to propose large-scale general measures for the population as a whole.
- Various parties can take measures that may improve the general immunity of systems in the home and equipment. This will have a generic positive effect on immunity to different types of interference, including interference caused specifically by mobile use in the 800 MHz band.

1

Introduction

With a view to use of the Digital Dividend, the European Commission intends to make the 800 MHz spectrum of the broadcasting frequency band (UHF) available for electronic telecommunication, with intended mobile broadband usage. However, this may cause interference to TV signals because the (LTE) mobile applications use frequencies also used in cable TV networks.

An initial exploratory study conducted by Radiocommunications Agency Netherlands in November 2009⁴ revealed an approximately 75% probability of LTE mobile applications causing interference to digital cable TV, assuming the existence of co-channelling. A supplementary study was necessary to identify the scale of the interference and, in particular, solutions to it. This report presents the results of this new study.

For the purposes of the study the following questions were formulated:

- to what extent may interference be caused to Dutch in-home cable TV systems due to introduction of LTE applications in the Digital Dividend band of 790-862 MHz?
- to what extent do possibilities exist for avoiding interference to cable TV in a person's own home and surrounding homes?

The Agency carried out the study in cooperation with the University of Twente. The two organisations each performed and reported some of the measurements. The Agency further examined the seriousness of the problem and the University looked at how it could be tackled. There was mutual verification of the results.

In this new study some assumptions made in the original study in 2009 have been adjusted, and the statistical probability of co-channelling (i.e. the condition required for interference to occur) now forms an integral part of the study.

This concerns interference caused specifically by use of a mobile handset that transmits in the sub-band of 790-862 MHz ('800 MHz') that can radiate into digital TV sets or set-top box at a person's home and possibly also those of other people like neighbours. Two matters are important in order to obtain the most realistic possible picture of this interference problem:

- firstly, there needs to be a good understanding and definition of the situation where interference may potentially occur;
- secondly, given the situation described above, it is necessary to find out how many households will actually be affected by interference.

Figure 1: The top four channels of the cable band overlap the 6 LTE uplink channels on which mobile handsets transmit⁵.

Mobile Service												
LTE Downlink Range 6 Channels à 5 MHz						Duplex gap 11 Mhz	LTE Uplink Range 6 Channels à 5 MHz					
791-796	796-801	801-805	805-811	811-816	816-821	821-832	832-837	837-842	842-847	847-852	852-857	857-862

Cable									
72 Mhz (9 Channels à 8 MHz)									
790-798	798-806	806-814	814-822	822-830	830-838	838-846	846-854	854-862	

⁴ Agentschap Telecom, *Study of interference to digital cable TV caused by 800 MHz mobile LTE applications; Report on 1st and 2nd sets of tests*, Report for DGET, Groningen, 27 November 2009.

⁵ The downlink channels on which base stations transmit did not form part of the study.

The first item refers to the 'co-channelling' situation. This is a situation where an 800 MHz mobile handset transmits on *the same* channel as the one to which a person has tuned his TV at that particular moment. For the occurrence of these 'coinciding channels', the following three conditions must be met simultaneously:

- 1 somebody must actively be using an 800 MHz mobile handset, which
- 2 selects the same channel as
- 3 the channel to which the TV is tuned at that particular moment.

A situation of 'coinciding channels', or co-channelling, will occur only if all three of these conditions exist simultaneously. It is the only situation where households might experience interference. Not every co-channelling situation actually interferes with the TV signal. On average this will lead in 48% of all cases where co-channelling exists at a household to noticeable interference to the TV station being viewed at that particular moment.

Therefore, this study consists of two parts. The first part describes the statistical probability of the occurrence of coinciding channels. The second part presents the results of the technical study into the probability of interference actually occurring, given a co-channelling situation.

Structure of report

Chapter 2 deals with the statistical probability of the occurrence of coinciding channels. An attempt has been made, under different assumptions, to provide the most realistic possible picture of the nature and scale of the probability of co-channelling.

Chapter 3 discusses the technical study that, given a situation of co-channelling, provides an insight into how much interference a TV signal may actually experience.

Chapter 4 looks at measures that consumers and stakeholders might be able to take to alleviate the problem.

Chapter 5 discusses the main international studies and gives an overview of the policy and approach adopted in some other European countries with regard to this kind of interference.

Chapter 6 ends the report with a conclusion.

2

Calculation of statistical probability of interference

This chapter describes the statistical probability of the occurrence of a situation where a household may experience interference. A consumer will experience interference only if at a certain moment a mobile handset is active in the 800 MHz band on the same channel to which a digital TV station is tuned at the same moment ('co-channelling').

2.1 Introduction

Consumers with cable television can now tune to numerous TV stations. The basic package alone includes approximately thirty stations. On average they are programmed in four channels of the entire cable band. Therefore, it was assumed for the purposes of this study that approximately seven or eight TV stations fit into one cable channel⁶. The entire cable band consists of 57 channels. A consumer who takes an extended extra package from his cable company will theoretically be able to tune to approximately 400 TV stations that he can view (57 x 7 stations). Statistically the probability of a person with an extended package being tuned at exactly the same moment to exactly the same channel as the one on which a mobile phone is active at that particular moment will then be smaller. On the other hand, if somebody has only a basic package and the cable company has *not* programmed the package's stations in the 'LTE channels', it will be impossible for these consumers to experience interference.

The channels designated for mobile telephony in the 800 MHz band are known. The most critical are the channels on which a mobile handset transmits. These are the four highest channels of the cable band. Interference can occur only in these channels, and only on TV stations programmed in those channels, at the time a mobile handset is active in the 800 MHz band.⁷

There are different groups of viewers with a different range of TV offerings. Therefore, this chapter calculates the probabilities in various scenarios. There are assumed to be two groups of viewers:

- 1 Consumers with only a basic package⁸
- 2 Consumers with an extended package in addition to a basic package.

For simplicity's sake, we have assumed that only one extended package exists. It consists of *all additionally available TV stations* outside the basic package. A person who in addition to the basic package has an extended package will thus have at his disposal all TV stations distributed across all 57 channels.

Which probabilities have been calculated?

This chapter is structured in the following way. First, there is a calculation of how high the probability of co-channelling is. This probability is then refined for different scenarios. What is the probability of co-channelling if we assume that

the stations of the basic package do or do not fall into the 'LTE channels'? Subsequently, we translate these interference probabilities into the real-life situation. On average how many households will be affected by interference on a TV evening, and how many simultaneously at a certain time in the evening?

As every TV viewer, in principle, runs the risk of coinciding channels (if an 800 MHz handset is used), we also calculated how often on average a person may find himself in this situation over a prolonged period of time (one year, for example). Finally, there is an examination of what this means for cable companies.

It is important to realise that not everybody may experience interference in a situation of coinciding channels. The TV signal will experience interference in, on average, 48% of all cases where co-channelling occurs (see chapter 3).

When calculating the different probabilities, we inevitably had to make certain suppositions and best guess assumptions. Different values will be shown for some of the assumptions to make transparent how the probabilities change at a different value of a certain assumption (e.g. different values for the degree of penetration of 800 MHz mobile telephony in the Netherlands).

2.2 Basic co-channelling principles

As interference can occur only if the LTE and TV frequencies come together, it is necessary to calculate the probability that an LTE mobile handset will use the same channel as the one on which a person is watching the TV at that particular moment.

Firstly, the mobile handset must select a frequency in the 800 MHz spectrum. The probability of such an occurrence was estimated in the following way. If it is assumed that the frequency bands available to the LTE mobile handset are 800 MHz and 2.6 GHz, approximately 30% of that spectrum consists of frequencies in the 800 MHz band. This is because there is 30 MHz available to the LTE mobile handset in the 800 MHz band and 70 MHz in the 2.6 GHz band (not including the unpaired spectrum in 2.6 GHz band). The probability of an LTE mobile handset using the 800 MHz band can then be estimated at 30%.

The other potential LTE bands, such as 900 MHz, 1800 MHz and 2 GHz Have not been included in this calculation, as it is unclear when they will be transferred to LTE technology.

⁶ In practice this figure may be higher or lower. Depending on the required quality of the TV signal, more or less TV stations may be programmed on one and the same cable channel.

⁷ The possible interference on the TV channels adjacent to the four that experience interference from LTE was disregarded because this interference does not significantly increase the total probability of interference.

⁸ It is estimated that the basic package contains about 30 programs.

Secondly, a 5 MHz channel selected in the LTE mobile spectrum must overlap the channel to which a TV station is tuned at that particular moment. The TV can choose from 57 channels of 8 MHz. The probability of the TV channel overlapping (or partially overlapping) the channel of the mobile handset is $4/57 \times 1/3 = 2.3\%$ probability.⁹

2.3 Different scenarios for the probability of co-channelling

Some elements that greatly influence this probability will only be known in the future. Therefore, it was decided to calculate the co-channelling probability in two scenarios (footnote 9). In the first scenario, we have assumed that the channels potentially causing interference are distributed randomly across all TV channels. In the second scenario, we have assumed that cable companies, when planning TV stations, will *not* program the most frequently viewed channels ('basic package') in the four TV channels on which an LTE mobile handset can cause interference. In both scenarios, we have assumed that digital television will be offered as a 'basic package' and 'extended package'. It has been assumed that all households will have digital television in 2015. We have further assumed that the basic package consists of thirty TV stations that in one way or another are distributed across 57 channels of 8 MHz. The probability that a person will make an LTE handset phone call and will select precisely a channel in the 800 MHz band was set at 30% (see para-

graph 2.2). The co-channelling probability is therefore the probability that the LTE mobile handset selects a channel from the 800 MHz band that overlaps a TV channel being watched at that particular moment by members of the same household.

Scenario I: Basic package stations are distributed arbitrarily across the TV band

Scenario I assumes that the 30 most frequently viewed television stations are distributed arbitrarily across the entire band and may therefore also fall into channels that may potentially be subject to interference caused by an LTE mobile handset (in scenario II the basic package falls outside the LTE part of the 800 MHz band). The reason for the difference in these scenarios is that we have assumed that there will be a relatively large amount of viewing of stations in the basic package and want to be able to evaluate the effect if these stations are not programmed in the LTE channels.

The premise in scenario 1 is that the basic package stations are distributed arbitrarily across the TV band. A 'probability tree' clearly shows the calculation of the co-channelling probability. In the tree below, there is a calculation of how great the probability will be in an arbitrarily chosen household of an active LTE mobile handset interfering with the television programme that people are watching at that moment.

Scenario I: basic package channels are arbitrarily allocated across the TV spectrum

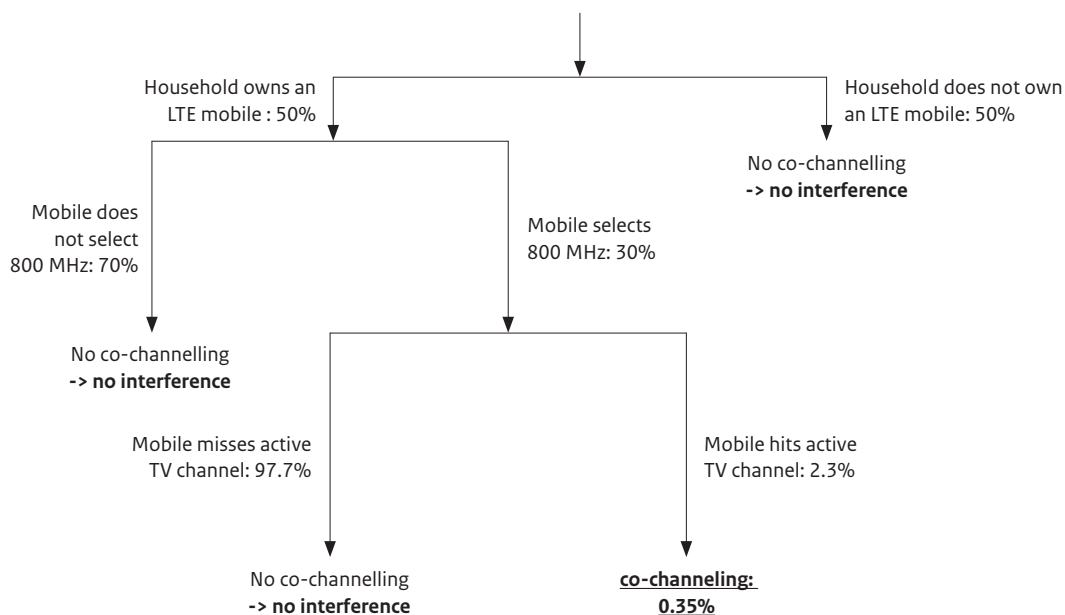

⁹ Because 4 of totally 57 TV channels are in the LTE uplink part and the probability of overlap with an active LTE channel (assuming an LTE bandwidth of 5 MHz) is $1/3$, because for every possible choice of one of these 6 LTE channels there will be an overlap with 2 TV channels. So, in every possible case there is co-channelling with 2 of 6 TV channels ($1/3$). The probability is therefore $4/57 \times 1/3 = 2.3\%$.

Explanation interference tree

A number of situations must occur simultaneously to get co-channelling in scenario I. These situations and their probabilities are presented (together with their complements) as a branch in the interference tree. For an arbitrarily chosen household to get co-channelling in scenario I, the household must possess an LTE mobile handset. This probability was assumed to be 50% (working on the assumption that half of all households will have a mobile handset with 800 MHz functionality five years after their introduction).¹⁰ Assuming that a call is made using the LTE handset, the handset must first select the 800 MHz band and then, precisely in the same 800 MHz band, the exact channel that overlaps with the TV channel being watched at that particular time. As these situations occur independently of each other, the associated probabilities must be multiplied by each other to obtain the ultimate probability of co-channelling. In the example shown above, the figures used result on multiplication in the ultimate probability of co-channelling (50% x 30% x 2.3% = 0.35%). In other words, if the 30 most frequently viewed television stations are distributed arbitrarily across all TV channels, the probability that co-channelling may occur at an arbitrarily chosen household in the Netherlands is 0.35%.¹¹

Scenario II: stations in the standard package do not fall in the channels of the LTE spectrum

The same method was used for scenario II. It was assumed in this scenario that the 30 most frequently viewed TV stations are *not* programmed in TV channels that potentially may be affected by interference by LTE mobile handsets.

The co-channelling probability was calculated as 50% x 20% x 30% x 1.2% = 0.035%, with the probability of a mobile handset affecting the active TV channel was calculated in the following way:

- the probability of a person possessing a subscription for 800 MHz LTE five years after introduction was estimated at 50% (i.e. half of all households);
- it was assumed that 20% of the households has an extended package;
- the probability of the LTE mobile handset selecting an 800 MHz channel when setting up a call is 30%;
- the probability of household with an extended package watching a station in the extended package was estimated at 50% (i.e. for half the viewing time the consumer will still be watching stations in the basic package);
- the probability of this station overlapping the LTE channel was set at $(4/57) \times (1/3)$ (at bandwidth of the LTE mo-

Scenario II: basic package channels do not fall within LTE reach

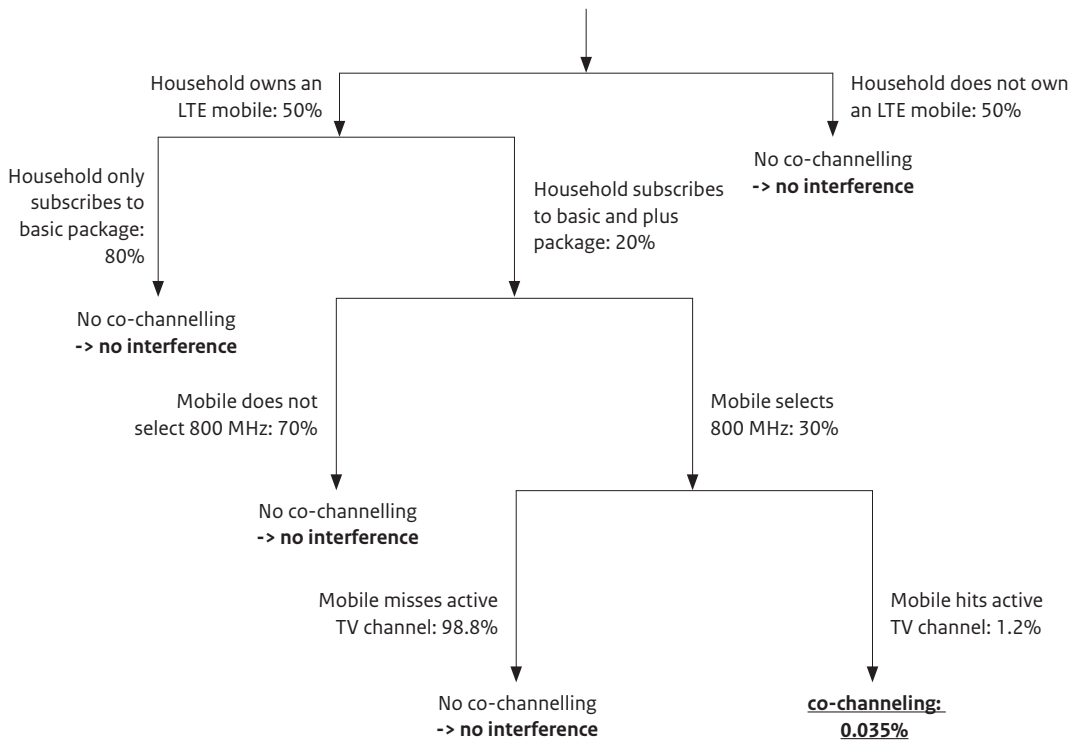

¹⁰ As the average household counts 2.1 persons, the penetration scale of LTE mobiles would be 24% of population.

¹¹ Of course presuming that the assumptions have been assessed correctly.

bile handset of 5 MHz). As half the time a viewer will still be watching a station in the basic package, however, this probability will be multiplied by 0.5: $(0.50 \times (4/57) \times (1/3)) = 0.012$, or in other words 1.2%;

- the ultimate co-channelling probability is therefore $50\% \times 20\% \times 30\% \times 1.2\% = 0.035\%$.

When calculating the different probabilities, we inevitably had to make certain suppositions and best guess assumptions. Different values were also used to make transparent how the probabilities change at values that differ from those of the best guess assumptions.

The tables below show the results for different sets of assumptions, A, B and C. The results under 'A' show the probabilities and assumptions also shown in the interference trees.

Table 1: statistical probability of co-channelling under Scenario I: basic package channels arbitrarily allocated across TV frequency band

	A	B	C
Households with LTE mobile	50%	50%	90%
Probability of 800 MHz	30%	50%	10%
Probability of co-channelling	0.35%	0.59%	0.21%

Table 2: statistical probability of co-channelling under Scenario II: basic package channels not allocated to LTE spectrum channels

	A	B	C
Households with LTE mobile	50%	50%	90%
Households with plus package	20%	50%	20%
Percentage plus package viewing time	50%	50%	80%
Probability of 800 MHz	30%	50%	10%
Probability of co-channelling	0.035%	0.15%	0.034%

By multiplying the co-channelling probability by the interference probability (given that co-channelling occurs; see chapter 3), you ultimately obtain the probability of interference actually being experienced. This is shown in the bottom row. The same was done for the interference probabilities under the assumptions of B and C.

Table 3: probability of actually experienced interference under Scenario I: basic package channels arbitrarily allocated across TV frequency band

	A	B	C
Probability of co-channelling	0.35%	0.59%	0.21%
Probability of interference	48%	48%	48%
Probability of experienced interference	0.17%	0.28%	0.10%

Table 4: probability of actually experienced interference under Scenario II: basic package channels not allocated to LTE spectrum channels

	A	B	C
Probability of co-channelling	0.035%	0.15%	0.034%
Probability of interference	48%	48%	48%
Probability of experienced interference	0.017%	0.070%	0.016%

Influence of external sources of interference

These probabilities were calculated based on the idea that the largest source of interference will be a person's own LTE mobile handset. But the interference may equally originate from a neighbour or a passer-by walking down the street. If these influences on the ultimate interference probability are factored in, it will be necessary to roughly double the probabilities stated above. Assuming that every household has on average one neighbour who possesses an LTE handset and who has the same calling patterns, it will be possible for interference to occur only if one of the two (i.e. household or neighbour, or both) is using the LTE handset and co-channelling occurs. As the separate probabilities are the same and relatively low, this leads roughly to almost a doubling.

2.4 Translation of interference probability to real-life situation

The average number of households that experience interference each evening is a figure that might provide a greater insight into the scale of the problem. By multiplying the interference probability by the average number of households in the Netherlands that watch TV on an evening, you obtain the potential number of households that will experience interference on an average TV evening. If we assume that, on average, a 800 MHz mobile handset will be used in a household to make two LTE calls per hour averaging three minutes, we can also determine the expected number of households that will experience interference at an arbitrarily chosen moment in the evening. The LTE mobile handset will be making calls averaging six minutes per hour in total. This is one-tenth of the time.

How often will a person experience interference?

Another figure that might increase the insight into this question is the number of times that a mobile handset must be used within a household before interference with TV reception is experienced for the first time. In other words, viewed over time, how long will it take before a household will be confronted by this type of interference?

The interference probability for this group is then calculable by multiplying the probability P that the active TV channel will affect the LTE channel by the probability of interference. The expectation value of the number of times that calls must be set up until occurrence of the first instance of interference is then roughly $(1-P)/P$. If we divide this figure by the average number of calls per afternoon/evening, we obtain roughly the number of days before interference will be experienced for the first time.

2.4.1 Scenario I: how many households will experience interference?

On the assumptions of situations A, B, and C we worked out:

- how many households may, on an average TV evening, experience interference to their TV signal, and
- how many households simultaneously experience interference at a certain moment in the evening.

Finally, we worked out how long it will take on average before a person might experience interference for the first time and, by consequence, estimated how long it will, (on average) take before it reoccurs.

On the assumptions stated at A (for scenario I), we made the following assumptions when working out these numbers of households:

- five years after its introduction half of all households will be using a mobile handset that uses the 800 MHz mobile spectrum (LTE);
- the probability of the handset selecting an 800 MHz channel when somebody makes a call with his mobile handset is again 30%;
- on average 3,000,000 households watch TV on an evening;
- on an average TV evening, people watch the television for three hours;
- the mobile handset is in use 10% of the time (two three-minute calls per hour);
- all TV channels are planned arbitrarily across the entire cable band. Therefore, every TV station can in principle be affected by interference, with no viewers being exempted from it. In other words, the TV channels were planned in the cable band without sparing the most frequently

viewed TV channels from potential interference (by not planning them in the interference-sensitive channels; scenario I).

Number of households that will experience interference on average TV evening

Suppositions:

- three million households watch television on an average TV evening;
- the probability of them experiencing interference is 0.17% (probability of co-channelling 0.35% x 48% probability of interference if co-channelling occurs; see table 3).

The number of households that, on average, will experience interference during an evening is therefore $3,000,000 \times 0.17\% \approx 5000$ households.

Number of households that will simultaneously experience interference at some moment in the evening

Suppositions:

- the mobile handset will be in use 10% of the time (two three-minute calls per hour);
- the probability of a person experiencing interference is 0.17% (0.36% probability of co-channelling x 48% probability of interference if there is co-channelling; see table 3);
- these figures must be multiplied by 3,000,000 households to calculate the number of people who will simultaneously experience this interference.

The number of households that will simultaneously experience interference at a certain moment in the evening is therefore the multiplication of the three figures stated above ($10\% \times 0.17\% \times 3,000,000$) ≈ 500 households.

Number of weeks until interference first occurs

The number of weeks that it is likely to take on average before interference occurs for the first time (and by consequence the time until the next interference occurs) provides an indication of how often over time a household will on average be affected by interference.

In this case the formula $(1-P)/P$ is the formula for the expectation value¹² of the number of calls until the first instance of interference. The expectation value applies only to a person who has a mobile handset with access to 800 MHz frequencies, so we will consider only the group that definitely has an LTE handset. For this group the interference probability is twice as high as the figure of 0.17% applied earlier (see table 4). This is because when examining this probability, we assumed that half the households would have an LTE mobile subscription. The outcome of the ex-

¹² Assuming a geometric distribution.

pectation value is the number of times that a person must make a call before experiencing interference for the first time. Dividing this figure by the number of calls per week (42) produces the average number of weeks before the first occurrence of interference:

$$((1 - 0,0034) / 0,0034) / (7 \times 6) \approx 7 \text{ weeks}$$

Notes to figures:

- 0.0034 is the probability of 0.17 % times 2.
- It was assumed that an average of 6 calls per evening will be set up (3 two-minute calls per evening) x 7 days.

Table 5: number of affected households under Scenario I that watch TV on an average evening

Scenario I: basic package channels arbitrarily allocated across TV frequency band

	A	B	C
Number of households simultaneously experiencing interference at a randomly chosen moment during the evening	500	840	300
Average number of households experiencing interference during the evening	5000	8400	3000
Number of weeks prior to the first occurrence of interference	7	4	21

Using the same assumptions we worked out the same probabilities in scenario II, where the 30 most frequently viewed TV stations in the channel line-up were not planned in channels in which an LTE mobile handset transmits.

2.4.2 Scenario II: how many households will experience interference?

Once again, subject to the assumptions stated at A (for Scenario II), we made the following assumptions in calculating the number of households:

- Five years after its introduction half of all households will own a mobile handset that uses the 800 MHz mobile spectrum (LTE);
- The probability of the handset selecting an 800 MHz channel when somebody makes a call with his mobile handset is 30%;
- 20% of households subscribe to a plus package;
- People in households with a plus package continue to view the basic package programmes 50% of the time;
- On average 3,000,000 households watch TV on any one evening;

- On an average TV evening, people watch television for three hours;
- The mobile handset is in use 10% of the time (two three-minute calls per hour);
- In Scenario II, the 30 most frequently watched TV programmes ('basic package') are not allocated to the 4 channels that are subject to potential interference by LTE mobile use in the 800 MHz band.

Number of households experiencing interference on an average TV evening

Assumptions:

- 3,000,000 households on an average evening .
- The probability of actual interference (0.017% see Table 4).¹³

The number of households that on a typical evening will experience interference is calculated by multiplying 3,000,000 x 0.017% = 500.

The number of households simultaneously experiencing interference at some moment during the evening

Assumptions:

- 3,000,000 households;
- 0.017% is the probability of interference whenever co-channelling occurs under Scenario II (see Table 4);
- The supposition is that the mobile handset is in use 10% of the time (two three-minute connections per hour);

The number of households that may simultaneously experience interference is then calculated by multiplying these figures: 3,000,000 x 0.017% x 10% = 50.

Number of weeks prior to the first occurrence of interference

For an explanation of this probability, see Scenario I.

$$((1 - 0.00034) / 0.00034) / (7 \times 6) \approx 70 \text{ weeks}$$

The 0.00034 figure is the multiplication of the ultimate probability of interference under Scenario II (0.017% x 2; see Table 4).

¹³ The probability of 0.0056% is the probability of interference when co-channelling occurs under Scenario II (a factor of 10 lower than 0.056%, see Table 4).

Table 6: Number of households affected under Scenario II, under different assumptions (A, B and C)

	A	B	C
Number of households simultaneously experiencing interference at a randomly chosen moment during the evening	50	210	49
Average number of households experiencing interference during the evening	500	2100	485
Number of weeks prior to the first occurrence of interference	70	17	133

An interpretation of the last probability of the two scenarios demonstrates that a household that owns an LTE mobile under certain assumptions will experience this type of interference about seven times per year, for the duration that the LTE handset is in use during that period. And that, under the scenario that the most frequently watched channels fall outside the potentially interfering LTE channels (Scenario II), this will be less than once per year.

2.4.3 Influence of behaviour of LTE handset users on the interference figures

The above scenarios and calculations consistently assume that the person owning an LTE mobile uses it on average two times per hour for a three minute call each time. This translates into active use of 10% of the time. It is also conceivable that user behaviour in the future will deviate from this pattern and that the number of calls per hour will be more or less and that the length of the call will be shorter or on the contrary, longer.¹⁴ This does not affect the calculated probabilities of interference, although it does affect the results presented in Section 2.4. These results can, however, be easily recalculated when we change the assumptions governing LTE usage.

If the number of calls per hour increases by a factor of x , then:

- The number of households simultaneously experiencing interference at a specific moment during the evening increases by this same factor x ;
- The total number of households experiencing interference on an evening increases by this same factor x ;
- The number of weeks until an arbitrarily selected household experiences the first occurrence of interference decreases by a factor of x .

If the average duration of a call increases by a factor y , then:

- The number of households simultaneously experiencing interference at a specific moment during the evening increasing by this same factor y .
- The total number of households experiencing interference on an evening increases by this same factor y ;
- The number of weeks until an arbitrarily selected household experiences the first occurrence of interference remains unchanged.

For example:

If the average number of calls is 10×3 minutes instead of 2×3 minutes per hour (in Scenario II under the assumptions at A), then:

- The number of households that simultaneously experiences interference at a specific moment during the evening is 5 times higher as well, i.e., $50 \times 5 = 250$.
- The total number of households experiencing interference on any evening is $500 \times 5 = 2,500$.
- The number of weeks until an arbitrarily selected household experiences the first occurrence of interference is 5 times smaller, i.e., $70 / 5 = 14$.

If the average duration of a call is 6 minutes instead of 3 minutes, while the average number of calls remains at 2 per hour (in Scenario II under the assumptions at A), then:

- The number of households that simultaneously experiences interference at a specific moment during the evening is 2 times higher as well, i.e., $50 \times 2 = 100$.
- The total number of households experiencing interference on any evening is $500 \times 2 = 1,000$.
- The number of weeks until an arbitrarily selected household experiences the first occurrence of interference remains unchanged, i.e., 70.

¹⁴ Mobile internet use is characterised by an expected asymmetry between uplink and downlink. Downloading will cause considerably less disturbance than uploading.

2.5 What do these probabilities mean for cable companies?

The different, partly individual probabilities of interference, presented above could camouflage the fact that from a macro perspective, cable companies may *always* be confronted somewhere with interference to one of the LTE channels. An estimate was provided in Section 2.4 of the number of households affected on an average TV evening and how many households this affects *simultaneously* at a specific time during the evening under two scenarios.

If we wanted to estimate the complaints the cable companies could potentially experience, these figures could be considered as indicative. Furthermore, it is important to review the nature of the interference. This is of a transient nature (for the duration that the LTE handset is in use during that period) and occurs under specific conditions (co-channelling). The number of households that experience interference during an evening varies between a few hundred and a few thousand, depending on whether the most frequently watched TV programmes are/are not considered during the planning of the relevant channels. At an arbitrary selected point in time during any evening, this number is projected to be between some dozens simultaneous cases of interference throughout all of the Netherlands and a few hundred incidents of interference, once again dependent on the most frequently watched TV programmes that are not allocated outside the LTE channels. Not everyone experiencing incidental interference will in fact complain. The problem solves itself as soon as the connection with the mobile handset is broken, or when someone switches TV channels.

The number of times that someone is expected to experience interference, *given the fact that someone is watching a TV programme allocated to the LTE channels*, has also been calculated. The probability that someone within a population, who is watching a TV programme allocated to the LTE band, will experience interference in Scenario I under the assumptions at A (see Section 2.3) is 2.5%.¹⁵ This is approximately 15 times higher than the general probability of interference of 0.17%. Whether the basic package then is within or outside the LTE band does not make any difference in this regard. This difference is due to the fact that here we are calculating the probability of interference *given the fact that someone is watching a TV programme that is allocated to a potentially interference-sensitive LTE channel*. The probability of experiencing interference in that case is of course higher.

The above increased probability of interference can be understood as follows. If 1,000 people are watching a specific TV programme allocated to a digital LTE channel, approximately 25 households under specific assumptions can expect to experience interference to that programme once that evening, for the duration that the mobile handset is in use during that period.

¹⁵ This probability is calculated as follows: $50\% \times 30\% \times 1 \times 1/3 \times 48\% = 2.5\%$. This is the same probability as in Table 3 under the assumptions at A. The only difference is that in this case the factor 4/57 is replaced by a factor of 1 because the TV programme being watched is consistently a programmed on a TV channel in the LTE frequency band.

3

Technical study of interference *if* co-channelling occurs

This section describes the probability of real-life TV signal interference when a co-channelling situation occurs. In other words, assuming that a co-channelling situation exists, what is the probability that there is real-life TV signal interference for the duration that the mobile handset is active during that period?

3.1 Introduction

An initial exploratory investigation carried out by the Agency in November 2009, demonstrates that the probability of interference caused to digital cable TV by LTE mobile applications is approximately 75%, provided there is co-channelling.¹⁶ To identify the magnitude of this interference and in particular identify solutions in greater detail, a follow-up investigation was necessary.

This section described the findings of the technical segment of this follow-up investigation.

The initial investigation was limited in terms of the types of homes, configurations and equipment analysed. It also had a number of limiting assumptions, and worst case and best case scenarios. The entire problem is mapped out in this report, categorised by type of home, without any worst case and best case scenarios.

The assumptions for the initial investigation were as follows: the LTE terminal transmits at a power level of 24 dBm (maximum), within the frequency band of the TV channel being watched, i.e., worst case, and the TV is fed by a good quality cable and has digital reception, i.e. best case. The generalisation of these assumptions means that statistical analyses are required. Monte Carlo simulations were used for this purpose. To perform these simulations required a model to be developed and a proper understanding of the interference mechanism. The measuring programme that separates the influence coefficients, equipment immunity and network interface mechanisms was designed to provide the necessary input into the model. The data used in the original investigation were incorporated into this follow-up investigation.

A number of assumptions used in the original investigation in 2009 were adjusted. For example, the assumption that a mobile handset always transmits at maximum power was dropped and the number of types of homes, configurations and equipment was expanded.

Basic assumption: Digital TV reception.

The analysis shows a difference in sensitivity between analogue and digital TV reception. Analogue TV transmission, in a situation of co-channelling, will almost always be interfered by LTE. The investigation assumed that in the future every household will have digital reception. The probabilities of interference and the numbers of interference

incidents presented (see previous section) are therefore based on this assumption. The estimate of the degree of interference and number of interference incidents can also be estimated for the transition phase, by replacing the probability of interference, after co-channelling, of 48% (digital reception) for a portion of the population that is still viewing analogue TV, with a probability of interference of 100% (analogue reception).

3.2 Approach to and method of study

The analysis methodology is characterised by its statistical approach.¹⁷ The parameters used for the calculations are all specified as statistical quantities, each with its own probability distribution. The calculation of an interference scenario consequently amounts to making a large number of calculations, for example thousands, whereby the parameters are extracted from their own distribution. The results of the calculations, 'interference' or 'no interference', are tracked. The 'interference' portion constitutes the interference probability for this scenario. The methodology described here is often used in science and industry and is known as the 'Monte Carlo Simulation'. The Monte Carlo Simulation requires that all parameters to be input are known, together with their statistical distribution. Data from research conducted by the Agency itself and by the University of Twente research partner were used for this analysis.

Various components of household TV installations using coax cable were analysed independently. This analysis shows that interference can be caused by the direct radiation from the mobile handset into the coax cable, as well as the set-top box. Both of these points of exposure to such radiation are defined as statistical variables. Furthermore, the distance of the mobile handset in the room in relation to the weakest point of the cable housing unit (generally the plug) and to the set-top box and TV is a determining factor in terms of the probability of interference.

¹⁶ Agentschap Telecom, *Study of interference to digital cable TV caused by 800 MHz mobile LTE applications; Report on 1st and 2nd sets of tests*, Report for DGET, Groningen, 27 November 2009.

¹⁷ A detailed description of the approach and method used for the technical analysis is contained in Annex 4. This annex also contains an explanation of the interference model and the parameters used.

In this respect, there are a number of variables that affect the probability of interference either positively or negatively:

- If a consumer has good quality cables and, in particular, good plugs inside the home, the probability of interference will be lower.
- If a consumer lives relatively far from a base station, the probability that interference occurs will be higher. In that case the power that the handset must generate to make contact with the base station will indeed be higher.¹⁸
- The greater the distance of the mobile handset to the key points of exposure to external radiation that cause interference (cables and plugs and set-top boxes), the smaller the probability that the use of a mobile handset will cause real-life interference.

A combination of these factors, together with the properties of the TV installation and any wall attenuation, jointly determine the ultimate probability of interference. These factors were all simultaneously input into a Monte Carlo Simulation and in this way the ultimate probability of interference was determined *when* co-channelling occurs.

3.3 Results of simulation

The table below displays the results of this simulation for a 5 MHz bandwidth.¹⁹

Table 7: probability of interference when co-channelling occurs for various types of homes at a 5 MHz bandwidth

	Living room	Influence of neighbours	Influence of passerby
Flat in inner city	51%	37%	n/a
Row house in suburb	50%	35%	32%
Stand alone home in suburb	50%	n/a	31%
Row house in countryside	46%	32%	27%
Standalone home in countryside	45%	n/a	27%

The calculations show that in a situation in which co-channelling occurs, there is a clear probability of interference for the viewer. The probability of interference is not only significant (average of 48%) when the interference is caused by a personal LTE mobile, an LTE mobile can also cause interference when it is operated by neighbours or on the street (average 34% and 28%, respectively). The probabilities of interference experienced due to neighbours and potentially a passerby are lower due to the attenuation of the walls and the distance of the source of interference to the home.

The probability of interference experienced by a viewer-consumer ultimately appears to be the multiplication of the probability of coinciding LTE and TV frequencies (probability of 'co-channelling', see Section 2) and the probability of real-life interference *when* a co-channelling situation occurs (see Table 7).

This analysis only considers the interference of LTE mobile telephones to cable TV networks. LTE base stations can also cause interference. In spite of the higher power levels, the probability of interference of base stations is negligible in comparison to the probability of interference due to mobile telephones. Annex 10 deals with this in greater depth.

Interference of LTE applications to digital TV via the ether (Digitenne) was also beyond the scope of this investigation. Annex 11 addresses the potential interference of LTE to DVB-T.

¹⁸ The higher the power, the higher the probability of interference to the digital TV signal (given a co-channelling situation).

¹⁹ Annex 4 also contains the probabilities of interference for the 1.25 MHz, 10 MHz and 20 MHz bandwidths. For the purpose of presenting this chapter we are assuming that the mobile operators will use a 5 MHz bandwidth for the distribution of LTE connections.

3.4 Description of process

This part of the investigation was conducted in collaboration between the Agency and the University of Twente. The measurements required for the model were also carried out by both organisations. See the Table below. The various measurements are described in detail in the annexes.

Table 8: summary of the sub-analyses and measurements conducted by the Agency and the University of Twente

Measurement or Analysis	Conducted by	Objective
Wall and floor attenuation	University of Twente	Data input for model
Coax materials observations	University of Twente	Data input for model
Disconnect measurement	University of Twente	Verification
Direct radiation from interference signal into TV and STB	Radiocommunications Agency	Data input for model
Shielding of TV and STB antenna input	Radiocommunications Agency	Data input for model
Interference of the LTE signal to the antenna itself	Radiocommunications Agency	Data input for model
Radiation into simulated coax networks	Radiocommunications Agency	Data input for model
LTE immunity in occupied homes	Radiocommunications Agency	Data input for model / verification
LTE immunity, improved installations	Radiocommunications Agency	Verification
Meta research in foreign research sources	Radiocommunications Agency	Verification

4 Measures

In terms of the measures to be implemented, the assumption made was that in view of the nature of the interference (in some circumstances of a transient nature), and the resulting frequency with which the interference is expected to occur, it is not evident that large-scale standard measures should be proposed for the population as a whole.

4.1 Introduction

With regard to the nature of the interference (under specific circumstances, of limited time) it is not inconceivable that most consumers will not come to the realisation that the interference they experience should be solved by implementing a number of measures, or that they will have the inclination to do so. This will certainly be true if this involves significant costs or effort. The measures described below in most cases therefore are *individual measures* for consumers who would like to clear up this form of interference experienced by them.²⁰

4.2 Measures that consumers can take

- In individual instances, a consumer may decide to replace the cables and plugs in his home.²¹ In half of the cases, the interference will then be resolved (although it is impossible to predict ahead of time whether this measure will be successful).
- Of the households that after this are still experiencing interference, they may decide to replace their set-top box with equipment of sufficient immunity. It is conceivable that the cable companies will make these set-top boxes available under certain conditions. It does not stand to reason that consumers in the first instance will replace their TV set. Only if the new TV set is a set with a built-in tuner would this make sense. It can be expected that in the future, once these newest TV sets are more predominant in households, they will have sufficient immunity.
- Femto cell technology, which involves the placement of a mini base station inside the home, results in a considerable reduction in the power generated by the mobile unit inside the home, thus reducing the probability of interference. This new service is still in its infancy, but could be very promising (also see TU Twente Annex).
- Distance of the mobile handset to the TV. Placing the LTE terminal further away from the TV or the set-top box reduces the probability of interference by approximately 20%.

4.3 Costs of measures

- Replacement of cables/plugs: € 40/consumer.
It is difficult to estimate how many households will decide to implement this measure. The interference, due to the character of co-channelling will occur ad hoc and will also go away by itself. The average household in the Netherlands can expect to be confronted with this form of

interference to the TV channel about 7 times each year, or less than 1 per year if the thirty most frequently watched TV programmes are not allocated to TV channels partially designated for the digital dividend. It is not inconceivable that most households when they experience interference will not realise that there is a problem that could or must be solved by implementing a number of measures, or that they will have the inclination to do so. This is why costs are shown per household as being the costs to an individual consumer if he/she is affected by this interference to an above average extent.

- Installation of an amplifier (€ 100/consumer).
The installation of an amplifier is only effective when someone does not replace his cables, and particularly his plugs. The installation of an amplifier in combination with good cables and plugs does not provide much additional gain in terms of immunity (indeed, the cables would then already be immune, see previous measure), although the digital TV or set-top box would in that case have a somewhat higher immunity. In view of the costs of an amplifier (approximately € 100), this measure as a rule will also not be a logical measure, if the immunity of the cables can also be improved on the basis of the first measure above (the replacement of cables, and particularly plugs at a cost of approximately € 40). Furthermore, the installation of an amplifier requires a degree of technical knowledge. If an installer is required to install the amplifier, this would add an additional € 100 in service costs. Furthermore, cable companies are not convinced of this type of immunity improvement.
- Replacement of set-top box: € 150.
Consumers are likely to only implement this measure if the replacement of the cables/plugs did not solve the problem. Here too it is difficult to estimate how many households this would involve. The projection is that this would involve households that, due to certain viewer behaviour and calling patterns in combination with an unfavourable living location in terms of sensitivity to interference are confronted with this type of interference to an above average extent.

²⁰ This section is based on an analysis carried out by the University of Twente under contract to the Agency to identify improvement measures and the associated costs (see Annex 3 for further information).

²¹ Particularly the quality of the *plugs* determines the level of exposure to external radiation and consequently the probability of interference. The cables analysed all appeared to be of reasonable quality. The difference was primarily in the quality of the plugs. A survey of a significant number of homes demonstrated that a large portion of households has such lower quality plugs inside their homes. Measurements were conducted in a laboratory setting using different types of plugs. The field survey is not entirely consistent with the measurement distribution in a laboratory setting, but the selected distribution is nevertheless largely comparable.

4.4 Effectiveness of measures

In terms of the effectiveness of the measures, due consideration must be given to the fact that in view of the nature of the interference (in specific circumstances, co-channelling) and the resulting opportunities, it is not evident that large-scale standard measures should be proposed for the population as a whole. The effectiveness of the measures described below therefore provides an indication of the effectiveness of the measure to be implemented by an individual consumer.

The interference model was used to work out the effectiveness of a number of measures for a various housing situations. In this chapter we give the effectivity of those measures for es a row house and a living room in a suburb. The probability of interference when co-channelling occurs on average is 48% without any measures.

Better cables and plugs in the home

In about half of the cases in which a consumer implements this measure, it solves the problem. To increase the immunity of the cables, it is also possible to install an amplifier. However, when a household has already improved its cabling, an amplifier will add relatively little in terms of further improvement. If the consumer decides to install an amplifier immediately (leaving his cables alone), the effectiveness will be of approximately the same magnitude as the improvement of cables and plugs inside the home: in approximately half of the cases, both measures will be effective.

Modification of equipment: set-top box

If one of the two measures described above does not have the desired effect, then the consumer can decide to replace the equipment inside his home. In most cases the set-top box will be the object of undesired exposure to external radiation, in view of the fact that there are still few TV sets with a built-in digital tuner installed in households. This is why the set-top box will be replaced in these instances. Of course this means that set-top boxes with sufficient immunity must be available on the market. At the moment, almost all set-top boxes and digital TV sets available on the market have insufficient immunity to the external radiation produced as a result of 800 MHz mobile use. The expectation is that over time this equipment will have sufficient immunity.

Consumers who implement all three measures will for all intents and purposes solve the problem. There remains a small residual probability of interference (0.2% in case co-channelling occurs) that is related to an unfavourable position within the living room (close to the TV or set-top

box) from which the mobile handset is used, in combination with the mobile handset's relatively high field strength, which in an extreme case can then still result in interference of the TV signal during that period.

4.5 Measures that other parties can take²²

Cable companies

Allocating the mobile LTE channels to the less frequently viewed channels reduces the problem for the average consumer by a magnitude of a factor of 10 or more. The costs associated with this measure are relatively low. In case of the digital transmission of TV signals, the consumer does not experience any drawbacks as a result of this. The redirection occurs within the digital set-top box and is consequently passed on to the TV set. Consumers do not need to re-program their TV to accommodate a new classification of channels.

The equipment industry

The industry must make an effort and/or sense the need for urgency to exclusively produce digital TV sets and set-top boxes with sufficient immunity. CENELEC–ETSI is working to establish improved immunity through means of standardisation at the European level.

Government

The government can provide incentives to ensure that consumers install good quality cables and plugs in their homes. This certainly applies to new homes or when someone moves. Good information provided in collaboration with various sector associations can contribute to consumer awareness of the importance of installing good quality cables/plugs in homes.

The government can also encourage industry to produce set-top boxes/decoders and TVs with sufficient immunity over time. CENELEC–ETSI is discussing the establishment of improved immunity through means of standardisation at the European level for this purpose.

Mobile network providers

Mobile network providers can facilitate the use of femto-cells. The femto-cell technology considerably reduces the power of the mobile handsets, and hence the probability of interference to the TV signal.

Mobile network providers could also make an effort to reduce the power generated by the handset through means of network planning. The investments involved in the further densification of the network could go as high as 300% of the original network investments.

²² In annex 3 a survey is given of the possible measures the various parties can take with their costs.

5 Foreign studies and policy

Little or no research into the degree of interference to TV signals caused by 800 MHz mobile applications has been conducted abroad. The impression is that most countries will free up the relevant channels for this new use or will reserve these channels for alternative uses such as the internet. In most countries there still appears to be sufficient room within the cable spectrum to be able to accommodate this. Cable companies in the Netherlands are indicating that there is little or no room to spare the LTE channels. A possible contributing factor in many other countries is that cable distribution is still considered a utility managed by government. Nevertheless, a number of investigations into this issue are known. Most investigations consider a specific component, such as direct radiation into equipment or the potential influence of neighbouring channels on the interference to LTE channels. This means that the results are only comparable at the component level.

5.1 Introduction

We nevertheless briefly highlight the investigations that we are aware of. We include an assessment for each investigation to identify whether the results match our results and the assumptions we adopted.

5.2 Foreign studies

Switzerland

BAKOM conducted research into the degree of interference due to 800 MHz mobile use to TV reception. The study followed similar reasoning to that used by the Agency. The probability of interference for the viewer in Switzerland is also highly dependent on the probability of co-channelling. If there is no co-channelling, there can be no interference.

In terms of the probability of interference after co-channelling, it is striking that some assumptions differ from our assumptions. For example, the study assumes a lower power transmission level for the mobile handset, i.e., generally below 14 dBm EIRP. This is based on Australian UMTS research that assumes a rural setting with, in addition to a village, a high placement of the base station. In Dutch rural settings, a base station serves larger surroundings. Furthermore, BAKOM assumes that the cable quality in accordance with EN 50083-2 extends through to the TV set. This standard is not mandatory for cable materials within the home. In general, inferior quality materials are installed within homes. Only with the emergence of KabelKeur did a comparable quality become available in the Netherlands. However, these cables are still far from installed in every home. This is why BAKOM estimates the probability of interference when co-channelling occurs to be lower than in our investigation, i.e., on average one interference incident per TV viewer per year. In combination with the probability of co-channelling, BAKOM concludes that the issue constitutes a limited and manageable problem that should not stand in the way of the introduction of 800 MHz mobile applications.

Although in our research, the probability of interference when co-channelling occurs is higher than in the Swiss situation, the overall probabilities of interference in our case are also relatively low because in our research the probability of co-channelling is also a key component in establishing the ultimate probability of real-life interference. In this sense, the findings of the Swiss research are comparable to our findings.

Cable Europe (Copsey)

This research was conducted by Copsey Communication Consultants under contract to the Association of European Cable Operators (Cable Europe) and is focused on the probability of interference when co-channelling occurs. This research demonstrates that potential interference is not only limited to the four LTE 800 MHz channels, but can also occur in the adjacent channels. The study does not take the probability of co-channelling into consideration. The study

computes the probability of interference as viewed from the perspective of cable distribution with the LTE power level set at 25 dBm EIRP as the worst case scenario. In other words, if the mobile handset generates that level of power, co-channelling occurs and consequently interference to the TV signal. The study does not calculate the percentage of the population that could experience interference. The presumption is that interference simply always occurs *under those assumptions*. The study makes recommendations designed to make the equipment more immune and in fact concludes that these channels are no longer suitable for TV distribution with the introduction of mobile use in the digital dividend.

Our study does not address interference to adjacent channels, because this interference does not significantly increase the total probability of interference.

IRT/ANGA

This investigation was conducted by the Institut für Rundfunktechnik (IRT) and the Association of German Cable Companies (ANGA). The research provides good insight into the LTE systems and performs measurements in an empty apartment. This research also indicates that interference to the co-channel channel and the adjacent channels can occur. The interference is assumed to always be present at a certain mobile handset power level. In addition, the study concludes that there is barely any difference between the effect of interference caused by neighbours or the direct interference caused by own use within the home. The Agency's research, however, demonstrates that there is a difference in the effect caused through own use (probability of interference of 48%), use by neighbours (34%) and passerby (28%). Furthermore, the IRT/ANGA study also analysed the effect of interference on other equipment in the home, such as camcorders. Here too, there is a call for further research into the immunity of equipment (set-top boxes, modems and digital TVs). And to improve such equipment in the future. The nature of this research strongly reflects that of Copsey.

BnetZA

Further to the research conducted by IRT/ANGA, BnetZA (Germany) conducted further research into radiation into equipment (set-top boxes, TVs and modems). A number of TVs, set-top boxes and modems were tested by exposing them to a field of radiation with LTE modulation. The research showed that there are significant differences in the immunity of these devices and with some exceptions that they are not immune starting from a certain level of power radiated into these devices. The study recommends improvements in the standardisation of equipment requirements in this area. The EN 55020 standard should be expanded to include equipment, so that the industry is obliged to comply with this new standard in the future. The BnetZA study did not show any difference between analogue and digital TV in terms of sensitivity. Both experienced

the same degree of interference. However, the study only analysed the direct radiation of the LTE signal into the TV. Only a single digital TV and a single set-top box turned out to have sufficient immunity. The results of the radiation into equipment are presented anonymously. The interference percentages we found (after co-channelling) are therefore primarily attributable to the radiation into the cable and the variable mobile handset power level assumed in our study. In contrast, BnetzA only assessed one potential object of exposure to radiation. Radiation into the cables was not included, and the study does not provide an overall description of the problem.

The Agency conducted similar tests for the radiation into equipment as well. The results are comparable with BnetzA's study. We also found major differences in immunity and in our study only one TV set and only one set-top box had sufficient immunity as well. Our findings are contained in Annex 6. Work is underway on the standardisation of better equipment requirements in the European context. The expectation is that this will lead to improved immunity of future TV sets and set-top boxes.

Improvement in the immunity of set-top boxes is expected to play a major role in the near future in reducing the digital TV reception's sensitivity to interference. The market for digital TVs with built-in digital tuners is still in its infancy, and the expectation is that it will still take a long time before the existing analogue TVs will largely have disappeared from Dutch households to be replaced by new generation digital TVs with a built-in digital tuner.

Europe – other

We are not aware of any other research into this issue. The Agency sent a questionnaire to other European sister organisations to enquire into their perception of this issue. A number of countries view it as a manageable problem that can easily be tackled by the cable industry with a different investment. Improvement in the cabling within the home is also considered an area for improvement.

The results of the questionnaire are summarised below.

5.3 Policy and approach in other countries

Around the time this report will be published, the 800 MHz band for mobile communication will be auctioned off in Germany. The initial rollout is expected to occur in the cities of Berlin, Hamburg and Bremen, where the system is expected to be operational one year from now. Due to the comparability of these agglomerations and their use of cable to the Randstad conurbation in the Netherlands, this rollout constitutes an opportunity that we should be watching carefully. Furthermore, it can be concluded that the

potential interference to cable TV networks in Germany has not resulted in an adjustment to the policy for issuing mobile 800 MHz frequencies or hindered it in any way.

To get an impression of the awareness and potential measures in other countries designed to solve interference issues, the Agency asked European telecom administrators to complete a brief questionnaire.²³ Nine European administrators answered the questionnaire (Belgium, Estonia, Finland, Hungary, Ireland, Slovakia, Czech Republic, Sweden and Switzerland). The results show a diverse picture. The results, based on these countries, are as follows:

- 1 Only 4 countries expect problems related to interference. The other countries have a low cable density or the relevant frequencies are not in use for cable.
- 2 Switzerland is the only country that conducted its own research, and the results are publically available.
- 3 Switzerland analysed the scope of the problem and concluded that the problem is not as serious as expected (at any arbitrary point in time there is a 90% probability of less than 23 interference incidents. At a point in time at which on an average evening many people are watching TV, the number of simultaneous interference incidents in Switzerland is approximately 17). For this reason, no general limitations will be imposed on the rollout of LTE.
- 4 In terms of precautionary measures, the most frequently cited measures are improved cabling inside the home, and TVs and set-top boxes with improved immunity. One country is considering reduced LTE power levels. Three (3) countries are proposing not to use the relevant channels on cable and one country emphasises the need for proper in-home installations in terms of the overall setup.
- 5 Only 1 country indicated that it has legal means to impose precautionary measures on cable, the others explicitly indicated that radio services have priority.
- 6 In most countries it is impossible to hold one specific stakeholder generally responsible for interference incidents: depending on the segment of the system that fails, the responsible party could be the cable company, the mobile operator, TV viewer, mobile telephone user, or the equipment's manufacturer.
- 7 In line with bullet 6, the party that will solve the issue in actual practice depends on the situation, but in general the approach used will involve the viewer and the cable company and only as a last resort will the authorities become involved.
- 8 In 5 of the 9 countries, an administrator is involved in one way or another in solving this type of interference incident.
- 9 The principle point identified was that cable distribution is not a radio service and therefore does not have a legal right to protection.

²³ ECC, *Questionnaire on Cable TV receivers affected by New Radio services in the 800 MHz Digital Dividend band*, Working group RA, RA1 on Enforcement, Helsinki, 26 March 2010.

Conclusion

The introduction of mobile applications in the 800 MHz band, the so-called Digital Dividend, can cause interference in the use of cable because these frequencies are also used by cable TV networks. This report addresses the degree to which such interference can affect the offer of digital TV on cable.

An LTE mobile, the most probable mobile application in the 800 MHz band, can only cause interference to TV reception if it in fact transmits at the same frequency in the 800 MHz band as the channel to which a TV programme is tuned *at the same time*. In reverse, LTE applications do not experience any interference from cable TV.

The probability that a household watching an arbitrarily selected TV programme and that is also using an LTE mobile will experience a situation involving interference is calculated. Assuming that the digital TV programmes are arbitrarily distributed across the TV frequency band, this probability is on average 0.17%. In case interference in fact takes place, this will be during the period that the LTE mobile is in use.

Calculations are made subject to various assumptions:

The figures presented below are averages for all of the Netherlands. In actual practice, there will be some consumers who, due to their specific situation, will experience interference to their cable TV reception more than the average, while other consumers will never experience interference.

The calculated probabilities assume that interference in the first place is caused by the use of the household's own 800 MHz LTE mobile in their home. It is however also possible for the interference to be caused by a neighbour's 800 MHz LTE mobile or that of an incidental passerby. If these influences on the ultimate probability of interference are included in the calculations, the probabilities presented as part of the findings would have to be approximately doubled to account for them.

	Scenario: the TV programmes are randomly distributed across the TV frequency band	Scenario: the most frequently watched TV programmes are allocated outside the LTE channels
Probability that a digital TV programme in an arbitrary household experiences interference during the period that a potentially present LTE mobile with a 800 MHz capability is in use:	0.17% (average of 1 in 600 households)	0.017% (average of 1 in 6,000 households)
Average number of households in the Netherlands experiencing interference on an average TV viewing evening:	5000	500
Average number of households in the Netherlands simultaneously experiencing interference at a randomly chosen moment during the evening :	500	50
Number of times that an arbitrary household that owns a LTE mobile on average experiences interference:	Seven times per year	Less than once a year

From this table it is clear that the number of TV viewers who experience interference due to the use of an LTE mobile can be reduced by approximately a factor of 10 if the cable companies allocate the most frequently watched TV programmes to outside the frequency channels in which LTE mobiles can transmit (832 - 862 MHz).

The probability that someone who is watching a TV programme *that is allocated to the LTE band*, experiences interference is 2.5%. This is approximately 15 times higher than the general probability of interference of 0.17%. This difference is due to the fact that here we are calculating the conditional probability, *given that someone is watching a TV programme that is allocated to a potentially interference-sensitive TV channel*. The probability of interference in that case is of course higher.

This report conducts research into the probability of interference to digital TV reception, to which all abovementioned figures apply. The probability of interference to analogue TV reception is approximately twice as high as the probability of interference to digital TV reception.

What can a consumer do him/herself to reduce the probability of interference? If a consumer in his/her specific situation experiences a higher than average probability of interference and wants to solve this problem, he/she could implement one of several measures:

- Replace the cables, particularly the plugs, in his/her home with materials of sufficient immunity. This would completely solve the problem for approximately half of these consumers.
- If the set-top box and TV sets in the future would also have sufficient immunity, then the problem, combined with the measure stated above, would be almost completely solved.
- Install a femto-cell, that makes the mobile's power to be reduced.

What could other stakeholders do to reduce the probability of interference?

- Cable companies in planning the allocation of the offer of cable programming could opt to as much as possible spare the mobile LTE channels. If the most frequently watched regular TV programmes (programmes in the so-called basic package) are *not* allocated to these channels, then the number of TV viewers who experience interference due to LTE use would drop by a factor of approximately 10.
- Over time, the industry must ensure that TVs and set-top boxes introduced to the marketplace are immune to exposure to radiation from 800 MHz frequencies.
- Mobile operators could make femto-cell applications available to consumers on adequate scale.
- Also, they could make an effort to reduce the power generated by the handset through means of network planning. The investments involved in the further densification of the network could go as high as 300% of the original network investments.
- Government may, by guidance and mediation, in dialogue with stakeholders groups, stimulate consumers to install cables and specifically plugs with adequate immunity. Also the government may, with the industry, stimulate that digital TV's, set-top boxes and decoders with adequate immunity, become available in the near future. To this goal they consider within CENELEC and ETSI to standardise this better immunity for the European market.

In view of the nature of the interference (that only occurs under specific circumstances and that is often due to the use of an LTE mobile owned by the household), it would not appear appropriate to propose general large-scale measures for the population as a whole.

It is recommended, that any real-life interference experienced be minimized as far as possible in consultation with the relevant stakeholders. The role of the cable companies is of key importance in this regard.

List of annexes

This report contains the following annexes:

- Annex 1: Measurements of wall attenuations
- Annex 2: Inspection of coax materials
- Annex 3: Summary of interference suppression measures
- Annex 4: Results of technical analysis of interference when co-channelling occurs
- Annex 5: Parameter list for computation model
- Annex 6: Measurements of television sets, set-top boxes and cable modems
- Annex 7: LTE parameters
- Annex 8: Evaluation of external research
- Annex 9: Cable networks - background
- Annex 10: Related aspects
- Annex 11: LTE interference to DVB-T
- Annex 12: Glossary
- Annex 13: Bibliography



Analysis of interference to cable television due to mobile usage in the Digital Dividend

Annexes

UNIVERSITY OF TWENTE.

This Report was created in cooperation with the University of Twente.

Annex 1: Measurements of wall attenuations

University of Twente

For the interference model, it is important to know the extent to which an outer wall, inner wall and the ceiling attenuate the LTE signal. This annex describes the methodology and results of the measurements of 'wall attenuation'. The wall attenuation measurements can be carried out in various ways. It was decided to determine wall attenuation through measurements in homes rather than by testing wall materials in an EMC room. The advantage of taking measurements inside homes is that it reflects the actual situation, including the soft furnishings within the home.

Testing setup

The testing setup consists of a transmitter that generates a broadband-type signal (3 MHz) at 840 MHz. The signal is then transmitted via a $\frac{1}{4} \lambda$ antenna mounted on a stand with a height of 1.5 metres. The output power is approximately + 10 dBm. Furthermore, there is also a receiver that measures the power received from the transmitted radio signal. The receiver consists of a $\frac{1}{4} \lambda$ ground plane antenna mounted on a stand with a height of 1.5 metres (adjustable) and a Rhode & Schwarz FSH6 (mobile spectrum analyser). The measurement accuracy of the testing setup is tested by reviewing the antenna pattern of both antennas. This shows that the accuracy of the received signal is +/- 1 dB.

The measurement procedure first calls for a reference measurement to be performed. The transmitter and receiver are placed 2 metres apart for this purpose. The fact that the radio signal is subject to a great deal of reflection in a home causes variations in the received signal. By varying the height and location of the receiver's antenna, the maximum received signal is determined. The measurement is then repeated with a wall between the transmitter and receiver, the wall measurement. This involves placing the transmitter 1 metre from the wall. Ditto for the receiver. The maximum received signal is determined by varying the receiver in terms of height and location in this case as well. The variance between the reference measurement and the wall measurement is the *wall attenuation*. The measurement is repeated 3 times for every wall, and the results are analysed using statistical methods.

Results

Reference measurement

The results show relatively major variances in the received signal during the reference measurements. From this it can be concluded that the environment (and therefore the indirect radio paths) has a major impact on the received power. The histogram below displays the measured power (in dBm). The mean value is -29.1 dBm with a standard deviation of 2.9.

Furthermore, for the 2nd measurement, the wall measurement, the same variations caused by the environment are assumed. This data can be used to correct the measured wall attenuations. This is accomplished by subtracting the variance of the reference measurement from the measured variance in the wall attenuation.

The interference model assumes 3 types of walls: inner wall, outer wall and ceiling/floor. The results are broken down by wall in the sections below.

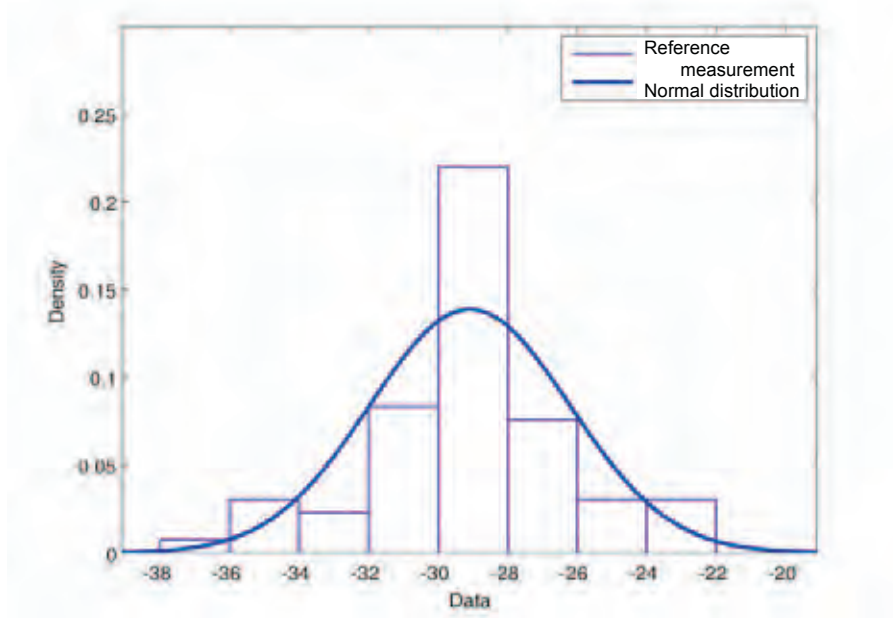

Inner wall

40 measurements were performed on an inner wall. This produced a total of 120 measurement points. The diagram below displays three lines; the histogram for the inner wall, a normal distribution based on the test data and a *corrected* normal distribution. The last curve makes the necessary corrections for the variations of the reference measurement. This produces a mean wall attenuation of 3.1 dB with a standard deviation of 3.4 dB.

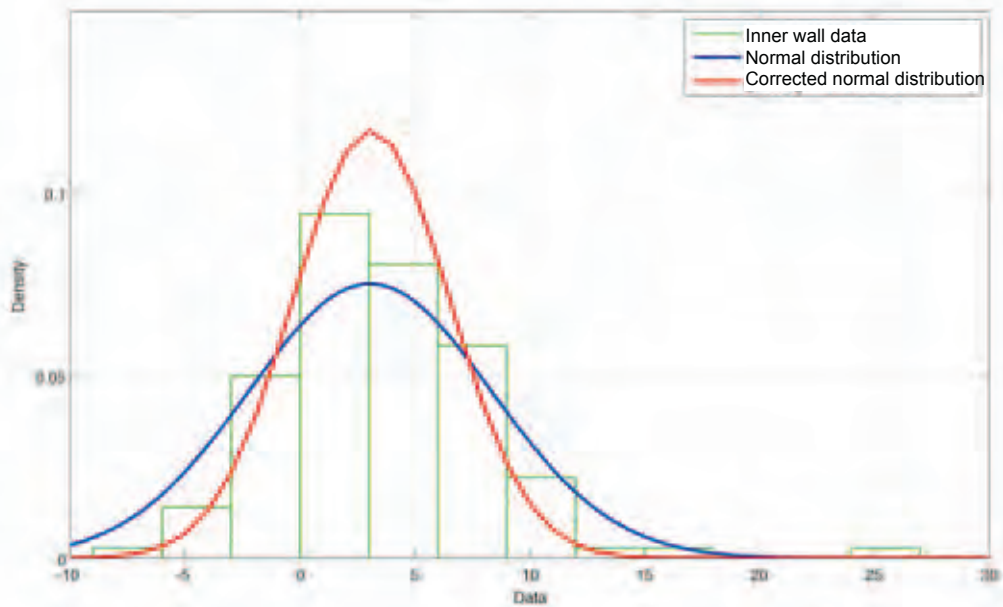

Outer wall

28 measurements were performed on an outer wall. This produced a total of 84 measurement points. This is illustrated in the diagram below using the same three lines as for the inner wall measurements. The mean wall attenuation is 7.2 dB with a standard deviation of 4.0 dB.

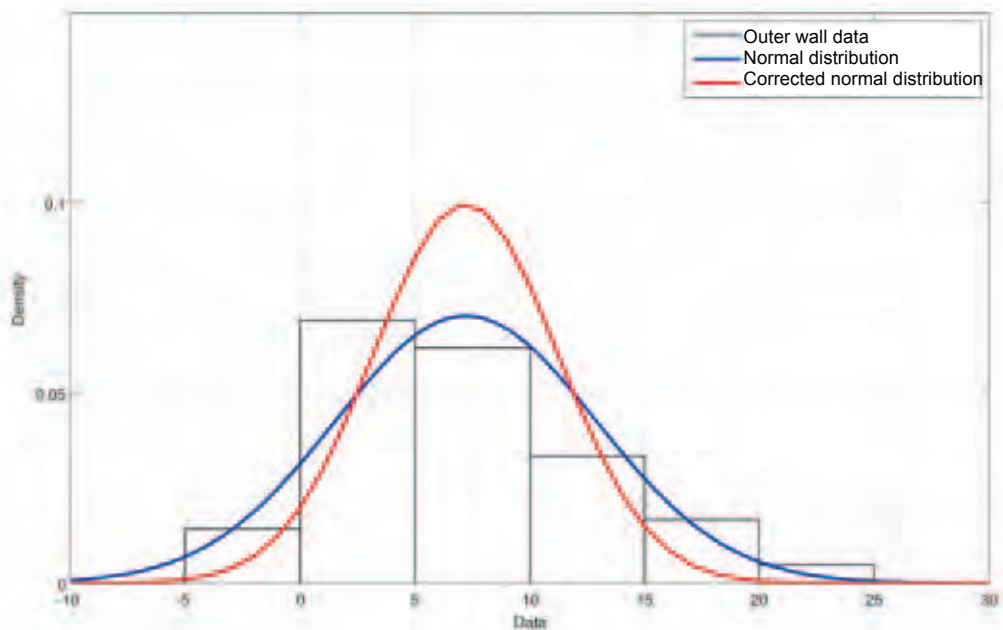

Ceiling/floor

21 measurements were performed for a ceiling/floor. This produced a total of 63 measurement points. This is illustrated in the diagram below using the same three lines as for the inner wall measurements. The mean wall attenuation is 5.5 dB with a standard deviation of 5.2 dB.

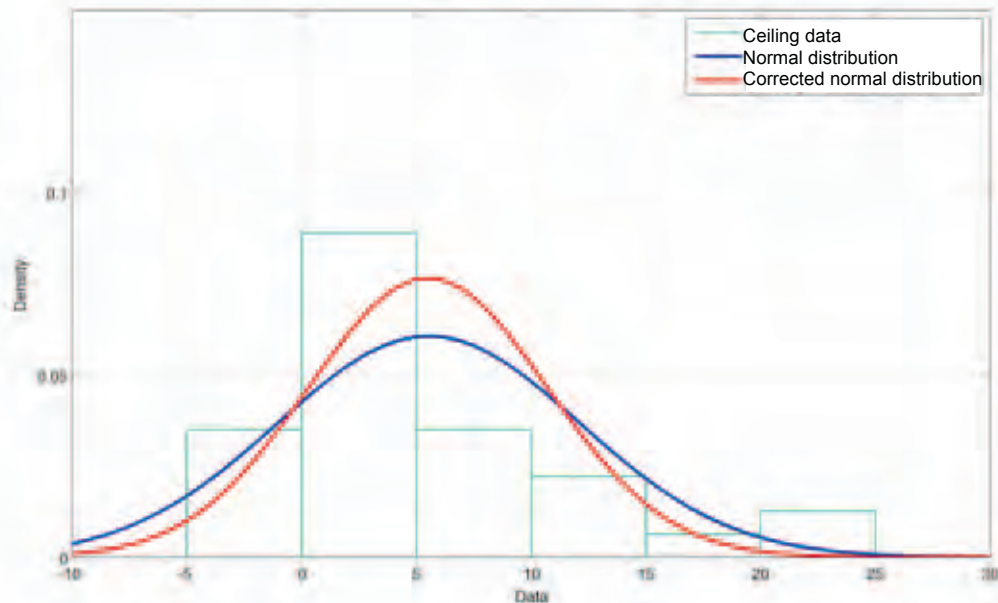

Comments on the results

From the tests it is evident that attenuation can vary enormously. On average, outer walls exhibit the highest attenuation, and inner walls have a lower level of attenuation. Furthermore, a striking finding is that ceilings have a relatively large spread. Attenuation is directly dependent on the building materials used and, for example, it turns out that concrete and reflective glass have a high level of attenuation. The raw test data furthermore shows that older homes in general exhibit the lowest level of wall attenuation. Finally, it is noted that in a number of cases, the attenuation was negative. This means that the signal received is stronger and is therefore not weakened by the wall. This same phenomenon is also noted in other literature. A key cause of this is the many reflections of the radio signal, as a result of which there are a large number of minima and maxima within a building. This not only results in large variations in the reference measurements, but also causes the attenuation to be negative in a number of instances.

Annex 2: Inspection of coax materials

University of Twente

The coax materials and type of antenna connector used in each home tested were also catalogued while the wall attenuation measurements were conducted. The quality of these materials affects the expected interference. Indeed, poor-quality coax cables are far more sensitive to interference.

The coax materials can be classified as follows: poor, standard and Kabel Keur/StAI, whereby the latter category is best. The poor category includes old coax materials, as well as poorly installed coax connectors. The connector used is also important. There is a distinction between an IEC connector with a plastic housing and an IEC connector with a metal housing, and an F connector with a plastic housing and an F connector with a metal housing. In this regard, the connectors with a metal housing have the highest level of immunity to external interference. A total of 29 homes were checked out. The results are presented below.

Connector Type	Quantity
IEC connector with plastic housing	14
IEC connector with metal housing	8
F connector with plastic housing	0
F connector with metal housing	7

Cable Type	Quantity
Poor	4
Standard	25
Kabel Keur/StAI	0

Comments on the results

As expected, most homes use a standard coax cable combined with an IEC connector with a plastic housing.

Annex 3:

Summary of interference suppression measures

University of Twente

Definition of terms used in this Annex:

CCP:	Customer Connection Point: cable connection point where the cable's signal enters the home.
STB:	Set-top Box.
LTE:	Long term Evolution: mobile telephone system designed to be the successor to UMTS that uses various spectra, including the 800 MHz band.
HDMI:	High Definition Multimedia Interface: digital audio and video cables and plugs that can be sensitive to interference from the direct radiation of 800 MHz signals.
Coax network:	the in-home installation consisting of cabling and plugs installed by the consumers themselves.

Introduction

The simulation model demonstrates that an LTE mobile telephone can generate significant interference to the cable TV system. The possible measures to reduce this interference, broken down by stakeholder, are identified below. This analysis only considers the interference of LTE mobile telephones to cable TV networks. Interference to digital TV broadcast via the ether (Digitenne) is not included. The interference of an LTE base station (downlink) that occurs in the neighbourhood of an LTE base station is also not included. Finally, the interference of LTE signals to HDMI cables has also been excluded. Indeed, other (foreign) investigations have shown that LTE signals can also cause interference to HDMI cables (digital video/audio cable) between the digital tuner and the TV. HDMI is a digital cable connection between different types of equipment, including the TV and the Set-top Box. HDMI assumes the functionality of the analogue SCART connector at this location. Unlike the SCART connector, longer cables are also supplied for HDMI. It is possible that this indeed causes immunity to deteriorate. To ascertain the impact of this more precisely would require further research in this specific area.

For each solution, the suppressed source of interference is identified: coupling into the coax network (coax network) or direct radiation to the equipment (direct radiation). The simulation model demonstrates that these sources of interference are approximately of the same magnitude. Furthermore, several scenarios were investigated: An LTE mobile telephone used in the living room by neighbours or on the street. It is evident that the highest level of interference occurs as part of the scenario involving the use of the LTE mobile telephone in the living room. Actually, the consumer therefore is the greatest source of interference; this means that the consumer causes interference to his own TV. There is less interference in the other scenarios. The solutions below should reduce the probability of interference in all scenarios proportionately.

1. Consumers

The coupling of the unwanted mobile LTE signal can occur in the coax cable network or directly into the equipment. Tests performed on consumer electronics show that levels of immunity differ significantly from one appliance to another. Furthermore, the findings also show that the private coax cable network is a weak point.

Potential solutions:

- Coax network: Replacement of the coax cable network.

Replacement of the private coax cable network with superior quality cabling (Kabel Keur), so as to reduce the impact of direct radiation.

Expected improvement: Standard coax cables have a minimum shielding of 60 dB, Kabel Keur cables have 75 dB and professional coax cables have a minimum shielding of 120 dB. In case of superior cables, the connectors (plugs) are usually the weak point. Professional IEC connectors have a minimum shielding of 85 dB and F connectors 90 dB. Overall, the use of professional cable can therefore suppress the interference signal by more than 30 dB in comparison to standard coax cable. This solution can be implemented immediately, and the average cost per household would be approximately € 40,-.

- Coax network: Ferrite beads

The placement of ferrite beads on the coax cable just ahead of the antenna input of the consumer appliance. This reduces the interference signal (the so-called common-mode RF currents).

Expected improvement: 3 to 8 dB reduction of the interference signal. This solution can be implemented immediately, and the average cost per household would be approximately € 10,-.

- Coax network & direct radiation: Cable TV repeater.

Installation of a cable TV repeater, so that the cable TV signal is less affected by the interference. This has to be installed properly, however, at a location within the network ahead from where the LTE signal feeds in. It is therefore recommended to place this repeater immediately at the CCP point.

Expected improvement: reduction of the strength of the interference signal by 15 to 30 dB. This solution can be implemented immediately, and the average cost per household would be approximately € 100,-. If this requires a technician, the cost increases by approximately € 100,- for labour costs. This measure is particularly effective when the cables and plugs have not yet been replaced. Indeed, if the in-home installation is already sufficiently immune, the improvement resulting from the repeater will not go very much beyond this, although the TV's immunity will improve somewhat due to the higher signal strength. Cable companies furthermore have indicated that they do not favour this solution.

- Direct radiation: Replacement of consumer TV electronics: set-top boxes, tuners, digital and analogue TVs with specimen with improved shielding properties.

Expected improvement: 20 dB (based on the results of direct radiation field trials).

In this context it should be noted that the set-top box qualifies for replacement in the first instance if the problem occurs with a more than average frequency. This is because most households do not yet have a TV with a built-in digital tuner ('digital TV'). In the European context, the target is to make new TVs sufficiently immune by specifying minimum requirements (standardisation), so that over time (2 to 3 years) the direct radiation to digital TVs is largely cleared up this way. Costs to replace a set-top box: approximately € 150,-. Should the TV nevertheless require replacement with a digital TV, the costs are approximately € 1,500,-.

Furthermore, it is reasonable to expect that in the future, the overall immunity of in-home installations will improve and consequently reduce the probability of interference. This is due to the purchase of newer consumer equipment as the older devices are written off. Furthermore, people tend to move from time to time, and the new home will often be equipped with a coax cable network installed in accordance with the latest insights. In relation to this last point, a trend is emerging whereby fibre optic cable is being used instead of coax cable. Fibre optic is impervious to radiation caused by radio frequencies.

2. Cable companies

The cable companies can also implement a number of measures to limit interference.

Potential solutions:

- Coax network & direct radiation: Transmit popular TV programmes in a different TV band segment.

Interference of course only occurs when the consumer is watching TV or recording a programme. By broadcasting the most popular TV channels outside of this band, the overall interference experienced by the consumer will decrease.

Expected improvement: the number of consumers experiencing problems will depend directly on the popularity of a TV channel. Typical reduction: by a factor of 10 or more. This solution has a typical lead time of 1 year and does not entail any direct or indirect costs. The cable company does have to inform its subscribers, however. This only applies to analogue channels. Most equipment designed for digital reception is capable of automatically regenerating the list of channels.

- Direct radiation: Use digital TV tuners/cable modems that are properly shielded.

The cable company in most cases supplies the equipment for internet and digital TV (digital tuner/cable modem). As such it holds the key to the expected interference. Namely by selecting equipment with better shielding properties, a potentially weak point is eliminated.

Expected improvement: 13 dB or more. This solution has a typical lead time of 3 years and the costs per connection point would be between € 10,- (cable modem) and € 150,- (set-top box).

- Coax network & direct radiation: Higher cable TV signal strength. Raising the cable TV signal strength so that the LTE mobile telephone causes less interference to TV reception.

Expected improvement: 20 to 30 dB reduction of the interference signal. This solution has a typical lead time of 3 years, and the costs per subscriber are difficult to estimate. The University of Twente estimates that these costs would be less than € 200,- per connection point and are for the account of the cable companies, considered as investment costs related to the network.

- Coax network & direct radiation: Replacement of analogue TV channels by digital channels.

Digital TV channels (DVB-C) are less affected by interference compared to analogue TV channels. The replacement of analogue TV channels by digital TV channels in the 790 to 862 MHz band reduces interference. This report already assumes digital reception. The use of analogue TV channels in this band therefore results in a deterioration of 20 to 30 dB. At the time of writing, the first cable company has halted analogue TV broadcasting. It is probable that other cable companies will follow within 5 years.

- Coax network & direct radiation: Increasing error protection in a digital TV channel.

Multiple digital TV programmes are transmitted on a single frequency. The modulation technique (e.g., QAM-64) and protection mode (error correcting layer) used determine the signal's degree of immunity to interference. Lowering the modulation technique or applying increased error protection would make the system more robust. However, this would be at the expense of available capacity. Expected improvement: 5 to 25 dB reduction of the interference signal. Greater reduction also results in decreased capacity (25% to 90% of a DVB multiplex). This solution has a typical lead time of 1 year. To be able to offer the same TV channels, the cable company would have to use more DVB-C frequencies. The associated costs are estimated at less than € 20,- per connection point (household) and are for the account of the cable company.

- Coax network & direct radiation: Freeing up of LTE uplink frequencies.

The interference model identifies LTE mobile telephone transmissions as the primary source of interference. The cable companies could free up the frequency bands in which the LTE mobile transmits. This band is a subset of the 790 – 862 MHz band. The rest of the channels can be used by the cable companies without any problems. Expected improvement: total elimination of the interference. This does however represent a reduction in the cable network's capacity of approximately 32 digital TV programmes (4 channels of 8 MHz, each of which can carry 8 TV programmes). This solution has a typical lead time of 1 year. The costs for this are estimated at less than € 40,- per customer connection point per year

and represent loss of income based on an estimate of a (portion) of the subscription cost for (digital) cable TV.

3. Regulations

The authorities too could consider a number of measures to counteract interference.

Potential measures:

- Coax network & direct radiation: The use of another frequency band for LTE, for example the 2.6 GHz band.

The LTE mobile communication system was designed for multiple frequency bands. In addition to the 800 MHz frequency band, the system is also suitable for the 2.6 GHz band. The 800 MHz band is primarily intended for communication in rural areas, while the 2.6 GHz band on the other hand is intended for urban areas (due to its higher capacity). In areas where the probability of interference is high, the government could limit use to the 2.6 GHz band only.

Expected improvement: complete elimination of interference in that area. The cost of this measure concerns the value reduction of the 800 MHz frequencies as a result of the inability to use it in urban areas. These costs are for the account of the government (lower auction revenues) or for the account of the licence holder should this measure be imposed retroactively.

- Coax network & direct radiation: Impose power restrictions on LTE mobile telephones.

An LTE mobile telephone causes the most interference when it transmits at maximum power (+23 dBm). The government could limit the maximum level of power. A second consequence of this of course is that this significantly reduces the reach of the LTE mobile telephone. One potential solution to this could be to use a Femto Cell base station. See point 4 below on solutions for mobile operators for further information on this.

Expected improvement: a reduction up to 20 dB. However, this does limit the reach of a LTE mobile telephone by a factor of up to 100. The costs of this measure consist of the additional costs required to densify the network. These costs can amount to as much as 300% of the original cost of constructing a network. This measure could be imposed before the licence is granted.

Aside from this, the wall attenuation tests show that new buildings attenuate radio signals to a greater extent (~10x) than old buildings. This is confirmed by other studies as well. For example, reflective and heat insulating windows attenuate radio signals as much as concrete. In newly built homes, the LTE mobile telephone's average transmission power will therefore be higher. (In addition, mobile operators will have to install relatively more transmission towers in new housing developments to provide sufficient in-home coverage. This applies to all mobile communication networks: GSM, UMTS, C2000 (TETRA), WiMAX, etc). A consequence of this is that, in the future, the number of incidents of interference caused by LTE mobile telephones could increase. It is

recommended that more research into 'mobile-friendly communication' construction materials be conducted.

4. Mobile operators

Mobile operators in the 800 MHz frequency band also have a number of opportunities to reduce interference.

Potential solutions:

- Coax network & direct radiation: Rollout of a hybrid LTE network with Femto Cells.

The capacity of a mobile network is primarily determined on the basis of the density of the base stations (transmission towers). An ultimate form of this is the use of Femto Cells. A Femto Cell is an LTE base station located in the consumer's own home. The product is connected in the home to a broadband internet connection and provides LTE coverage in and around the home. The advantage is that in such instances, the LTE mobile telephones is in close proximity to the base station as a result of which the transmission power will be significantly lower. This therefore reduces interference. On the other hand, this solution could cause additional interference when LTE mobile telephones on the street communicate with a Femto Cell base station located in the home. In such cases, the Femto Cell base station will transmit at maximum power. It is therefore important that a mobile operator constructs a network consisting of regular base stations (transmission towers) combined with Femto Cell base stations.

Expected improvement: typical reduction of 20 dB of the interference signal. The costs of this solution are less than € 60,- for each customer connection point/subscriber. This cost is based on the Femto Cell solution that Vodafone is currently offering in the United Kingdom for a UMTS network (Vodafone Sure Signal).

- Coax network & direct radiation: Construction of a densified network in problem areas.

Interference primarily occurs when the LTE mobile telephone transmits at maximum power. By densifying the network with additional transmission towers, the LTE mobile telephone's (average) transmission power will decrease and consequently the level of interference as well.

Expected improvement: 6 to 15 dB reduction of the interference signal. The costs involved in this solution are nil, provided that this improvement is implemented as part of the work required to increase the network's capacity. If this is not the case, the network costs could be as much as 300% higher.

- Coax network & direct radiation: The use of another frequency band for LTE, for example the 2.6 GHz band.

The areas where the probability of interference is high primarily consist of urban areas. An operator can avail himself of the 2.6 GHz band instead to avoid interference.

Expected improvement: total elimination of the interference. The costs consist of a value reduction of the 800 MHz frequencies due to the inability to use them in urban areas.

5. Producers of cable TV/internet equipment

Direct radiation:

Finally, the producers of TVs, set-top boxes, tuners, modems, etc, can also help to ensure that there is a reduction in the interference caused by LTE signals. Experiments conducted by the Radiocommunication Agency NL show that there are significant variances in shielding properties. The superior equipment has sufficient shielding.

Expected improvement: 20 dB or more. Due to the emergence of communication networks in the 800 MHz band, producers of this electronic equipment are becoming aware of these interference problems. In the meantime, the first steps have been taken to establish shielding criteria as part of a new standard for consumer equipment. The University of Twente expects that consumer equipment produced in 2 to 3 years will have significantly better shielding properties.

Annex 4: Results of technical analysis of interference when co-channelling occurs

Radiocommunications Agency Netherlands

Introduction

The use of LTE mobile terminals can cause interference to the cable TV of the LTE user himself or that of his neighbours, when the frequencies coincide.

Interference is expected to digital cable TV reception. This is dependent on the configuration of the disrupted equipment, the environment, the type of home and on the location of the LTE terminal when the interference occurs. The probabilities of interference are displayed in the following table.

Based on the selected interference model, the probabilities of interference for the various scenarios, environments and type of homes were calculated for a number of LTE bandwidth settings.

Environment	Home	Scenario	1.25 MHz	5 MHz	10 MHz	20 MHz
City	Flat	Living room	0.37	0.51	0.50	0.50
City	Flat	Neighbours	0.25	0.36	0.36	0.37
City	Flat	Upstairs neighbours	0.27	0.38	0.37	0.39
Suburb	Row	Living room	0.38	0.50	0.50	0.49
Suburb	Row	Neighbours	0.25	0.35	0.36	0.37
Suburb	Row	Street	0.20	0.32	0.32	0.33
Suburb	Detached	Living room	0.37	0.50	0.50	0.51
Suburb	Detached	Street	0.20	0.31	0.31	0.33
Countryside	Row	Living room	0.31	0.46	0.45	0.46
Countryside	Row	Neighbours	0.21	0.32	0.33	0.34
Countryside	Row	Street	0.15	0.27	0.27	0.28
Countryside	Detached	Living room	0.32	0.45	0.46	0.45
Countryside	Detached	Street	0.15	0.27	0.27	0.28

The calculations show that in a situation in which co-channelling occurs, there is a clear probability of interference for the viewer. The probability of interference is not only significant (average of 48%) when the interference is caused by a personal LTE mobile, but an LTE mobile can also cause interference when it is operated by neighbours or on the street (average 34% and 28%, respectively). The probabilities of interference experienced due to neighbours and potentially a passerby are lower due to the attenuation of the walls and the distance of the source of interference to the home.

The probability of interference experienced by a viewer-consumer ultimately proves to be the multiplication of the probability of coinciding LTE and TV frequencies (probability of 'co-channelling', see Section 2) and the probability of real-life interference *when* a co-channelling situation occurs (see Table).

This analysis only considers the interference of LTE mobile telephones to cable TV networks. Interference to digital TV broadcast via the ether (Digitenne) has not been included. This also applies to the interference of an LTE base station (downlink) that occurs in the neighbourhood of an LTE base station. The potential interference of LTE 800 MHz to DVB-T is separately addressed in an Annex.

Approach and structure of the analysis

The analysis as a whole was focused on distinctly identifying the different probabilities encountered by the viewer-consumer and the cable distributor. The probability of interference experienced by a viewer-consumer turns out to be the multiplication of the probability of coinciding LTE and TV frequencies and the probability of interference experienced by the cable distributor.

The probability of coinciding LTE and TV frequencies is small and is in part also determined by sociological factors, such as viewing behaviour, calling behaviour and the popularity of TV channels.

The probability of interference experienced by a cable distributor is the result of an analysis methodology characterised by its statistical approach. The parameters used for making the calculations are all specified as statistical quantities, each with its own probability distribution. The calculation of an interference scenario consequently amounts to making a large number of calculations, for example thousands, whereby the parameters are extracted from their own distribution. The results of the calculations, 'interference' or 'no interference', are tracked. The 'interference' portion constitutes the interference probability for this scenario. The methodology described here is often used in science and industry and is known as the 'Monte Carlo Simulation'.

The various interference scenarios were analysed by calculating them on the basis of the selected interference model. It is also possible this way to analyse interference scenarios with the assumption that the immunity of the TV sets or the shielding of the cable has been improved or that the transmission power level of the mobile terminals has been reduced. This makes it possible to establish the effectiveness of an improvement proposal.

The Monte Carlo Simulation requires that all parameters to be input are known, together with their statistical distribution. Data from existing literature and from research conducted by the Radiocommunications Agency NL itself and by the University of Twente research partner were used for this analysis.

In addition we need to know the various ways in which the interference operates; or how does the interference signal generated by the LTE mobile terminal attain the circuits of the TV set or the set-top box (STB). We refer to this as the interference model. The interference model is subsequently expressed in the form of algorithms (programmed) and forms the basis for the Monte Carlo Simulation. The interference model is extensively described and rationalised in Section 5.

A key result of the analysis is that we now have access to a computation model. It also means that we now have an understanding and insight into this phenomenon and can easily answer future questions.

Interference model

To identify the interference caused by LTE applications to the service provided by cable companies, an interference model was developed that attempts to take the various factors that could affect the various problem areas into account. This section first provides a global description of the model. This is followed by a detailed description of the parameters, including the rationale for the various choices made.

The computations are based on an LTE mobile located somewhere in the vicinity of a living room where the TV viewer is situated. The living room contains an STB/TV connected to the cable network via a cable. The LTE can cause interference in one of two ways. First, the cables in the living room can pick up the LTE's signal. This signal can couple into the inside of the cables and in this way can interfere with the wanted signal supplied by the cable network. A second way in which interference can occur is that the LTE's signal can radiate directly on the TV or STB, thus causing interference.

We assume that the LTE does not always and everywhere transmit at maximum power, but that the level of power is controlled by the base station.

The interference is calculated for a number of scenarios or locations where the interfering LTE mobile is located:

- In the living room
- With neighbours (in case of a row house or flat)
- With upstairs/downstairs neighbours (in case of a flat)
- On the street

The scenarios, where relevant, were reviewed for three types of homes:

- Detached home
- Row house
- Flat

Furthermore, where relevant, three different environments were considered:

- City
- Suburb
- Countryside

The diagram below illustrates the structure of the interference model. The TV signal can be disrupted in one of two ways:

- Via direct radiation, and
- Via coupling into the coax cable network.

In both cases the interference is directly dependent on the LTE mobile telephone's transmission power. This transmission power is next determined by the environment in which the telephone is located. Key factors that determine the level of power are the path loss with the base station and the minimum SNR. In case of a large distance between the base station and the mobile telephone, the path loss is great and the mobile telephone will have to transmit at high power to be able to communicate with the base station. The path loss in the interference model is determined on the basis of the channel model used.

The second parameter that determines the level of transmission power is the minimum SNR (signal-to-noise ratio). This parameter is determined by the design of the LTE (base station) network. If the network is designed for high capacity, the minimum SNR will be high. The next section deals with an expanded list of parameters used by the interference model.

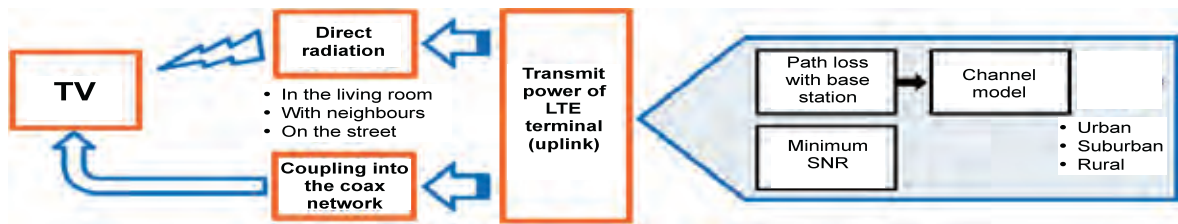

LTE Power

The assumption made for the LTE's level of power is that this is controlled by the base station. Different strategies are possible for this that result in different distributions of the LTE's power. The LTE's power in any event is limited to 25 dBm (consistent with the 800 MHz Decision of the European Commission: 'Commission Decision 2010/627/EU on harmonised technical conditions of use in the 790-862 MHz frequency band for terrestrial systems capable of providing electronic communications services in the European Union'). The assumption made by this computation model is that the LTE will transmit at the minimum power required to ensure good quality reception or service by the base station. The base station must receive a signal strength that is at least equal to the sensitivity of the base station for this purpose. In actual practice, transmission occurs at a somewhat higher power level, taking the protection ratio into account. In theory, the values of this offset are found to be between 0 and 15 dB. A value of 5 dB was selected for the model. Other parameters that play a role in controlling the power of the LTE is of course the attenuation experienced by the signal between the LTE and the base station and the operation of the antenna of the base station and the LTE.

The attenuation consists of signal loss as it passes through an outer wall and the path attenuation. Two propagation models are used to calculate the path attenuation, i.e. COST231 Hata for urban and suburban areas, and Recommendation ITU-R P. 1546-4 for the countryside. The radius of the service areas is also dependent on the environment. A spread of 8 dB for reflections and the like is taken into account for propagation.

Location

We assume that the TV/STB is located in a 7 x 4 metre living room. The cable is installed along one of the shorter sides of the living room. For the purpose of the computations, a minimum distance of 0.5 metres to the cable/STB is maintained. The neighbour's living room is assumed to be adjacent. Depending on the location of the cable/TV, the position of the LTE can then be between approx 0.5 and 14 metres. In terms of the upstairs neighbours, a similar room is assumed, but then 3 metres higher. In terms of the location on the street, the decision was to position the LTE between 0.5 and 7 metres from the window (as a result of which the distance can also vary between approx 0.5 and 14 metres).

Propagation LTE-STE/Cable

The free space model is used for calculating the propagation between the LTE and the cable or set-top box. On top of this, a standard deviation of 8 dB is used to take account of the reflections and attenuations in the room where the LTE or TV is located. Where applicable, the wall attenuation is identified.

Wall attenuation

The model takes account of wall attenuation. For the calculation of the propagation loss between the LTE and the base station, the model takes account of the signal loss through to the outer wall (except of course in the scenario in which the LTE is located on the street). For the path calculations between the LTE and the cable/STB, the loss due to the inner wall is taken into account (for the neighbours scenario), the outer wall (street scenario) and the ceiling (upstairs neighbours scenario). Wall attenuation is dependent on the type of home. The values were measured by the University of Twente.

Direct radiation to the cable

A series of measurements was used for the coupling or direct radiation to the cable. The power of the interference received at the signal port of a TV was measured in a test environment, whereby various cable configurations, cable qualities and transmitter positions were used. These parameters were incorporated into the model.

TV/STB Protection Ratio

The protection ratio of a number of televisions and set-top boxes was measured. The mean and standard deviation for the co-channel protection ratio was calculated on the basis of these measurements for each uplink bandwidth. Furthermore, the simulation assumes that when there is overlap between the LTE and TV/STB in terms of frequency use, the co-channel protection ratio applies. If there is no overlap in use, it is assumed that no interference will be experienced. This is a simplification of the bathtub curve that results from deteriorated immunity as the interference signal and the wanted signal assume a more similar frequency.

Immunity to direct radiation of the STB/TV

The immunity of a number of STBs and TVs was determined. It is striking that only a single TV brand and a single STB brand demonstrate higher immunity than the remaining appliances. These have not been used for calculating the mean and standard deviation. For the rest of the measurements, it was assumed that these follow a logarithmic normal distribution.

LTE Frequency

The LTE frequency was selected from the uplink band as specified in CEPT Report 30. The frequencies fall between 832 and 862 MHz.

STB/TV Power

We assume that the STB/TV is coded in an 8 MHz block in the 790 to 862 MHz range. Due to the fact that the LTE as well as the TV/STB independently select their frequencies, there is a probability of co-channelling. This is directly used as a multiplication factor in calculating the probability of interference. It is of key importance to recognise this.

Annex 5: **Parameter list for computation Model**

Radiocommunications Agency Netherlands

The parameters used for the computation model are as follows.

Parameter	Dependence	Value	Comments
Maximum LTE power		25 dBm	CEPT Report 30
Sensitivity of base station	Bandwidth<2 MHz Bandwidth>=2 MHz	-106.8 dBm -101.5 dBm
Offset in excess of sensitivity		5 dB	
Wanted signal		-53.4 +/- 9.2 dBm	Logarithmic normal distribution, based on TU Twente measurements
Base station gain		15 dB	CEPT Report 30
LTE gain		0 dB	
Radius of service area	Countryside	3460 m	CEPT Report 30
	Suburb	2698 m	CEPT Report 30
	City	2698 m	CEPT Report 30
Height of base station	Countryside	50-70m	CEPT Report 30
	Suburb	25-35m	CEPT Report 30
	City	25-35m	CEPT Report 30
Wall attenuation – outer wall	Flat	3.3+/-2.1 dB	TU Twente measurements
	Row house	7.3+/-4.1 dB	TU Twente measurements
	Detached home	7.3+/-4.1 dB	TU Twente measurements (on the basis of a row house)
Wall attenuation – dividing wall	Flat	4.5+/-3.2 dB	TU Twente measurements
	Row house	6.9+/-4.7 dB	TU Twente measurements
Attenuation of floor/ceiling	Detached home	4.2+/-1.2 dB	TU Twente measurements
	Flat	7.2+/-7.1 dB	TU Twente measurements, on the basis of all measurements to floors/ceilings
Cable coupling factor		-92 – 62 dB	On basis of test measurements (see..)
LTE basis post propagation	City	Cost231 Hata	Plus 8 dB normally distributed spread
	Suburb	Cost231 Hata	Plus 8 dB normally distributed spread
	Countryside	P1546	
Immunity to direct radiation	Bandwidth=1.25 MHz	Log(E)=0.41+-0.45	Logarithmic normal distribution
	Bandwidth=5 MHz	Log(E)=0.32+-0.41	Logarithmic normal distribution
	Bandwidth=10 MHz	Log(E)=0.36+-0.42	Logarithmic normal distribution
	Bandwidth=20 MHz	Log(E)=0.44+-0.40	Logarithmic normal distribution
Dimensions of living room		7x4x3 metres	(length x width x height)
Height of mobile		1.5 metres	Above the floor
Co-channel protection value	Bandwidth=1.25 MHz	-12.9 +/- 2.5 dB	Supervision of measurements
	Bandwidth=5 MHz	-19.2 +/- 2.9 dB	
	Bandwidth=10 MHz	-19.7+/- 3.1 dB	
LTE frequency	Bandwidth=20 MHz	-21.1 +/- 2.7 dB	
		832-862 MHz	Block dependent on bandwidth. See CEPT Report 30
STB/TV frequency		790-862 MHz	One of the 8 MHz blocks

Note 1. The abbreviated expression a +/-b is defined as an average 'a' with a spread 'b'.

Note 2. Logarithmic normal distribution means that the value dB follows a normal distribution.

Annex 6: Measurements of television sets, set-top boxes and cable modems

Radiocommunications Agency Netherlands

Introduction

Tests were performed in support of the Digital Dividend, involving a number of television sets, set-top boxes and cable modems. The tests relate to a number of electrical properties of these devices. The devices carry a CE label, which means that they must comply with a number of requirements. Some of these requirements were tested. Part 1 describes a number of general aspects that apply to all tests. Part 2 describes the shielding of tuners. Part 3 is devoted to the degree of influence of an unwanted signal at the input of a tuner. The sensitivity of devices to HF fields is described in Part 4. The results of the abovementioned tests are translated into factors affecting in-home networks in Part 5. The difference in the density of different types of electrical cords is summarised in Part 6. This annex concludes with a number of appendices.

Summary

A number of tests was performed on televisions sets (TVs), set-top boxes (STBs) and cable modems (CMs). The tests are identified in the various European standards as being applicable to such devices if they carry a CE label. 9 TVs, 6 STBs and 3 CMs were subjected to testing.

The video or audio information enters the tuner of (digital) TVs, set-top boxes and CMs at high frequencies. The tuner must have a certain degree of shielding against high frequencies. The tests show that two set-top boxes are not compliant with this requirement.

Wanted as well as unwanted signals may be presented at the tuner's input. The analysis assessed the impact of unwanted signals at the same and at other frequencies as the wanted signal. The bandwidth and modulation type of the unwanted signal are determining factors in terms of the impact on the wanted signal.

The devices must to a certain degree be immune to the high frequency fields present in their environment. Except for one device, they all meet this criterion.

The influence of the abovementioned factors are translated into corresponding impacts on in-home installations. Barely any impact is perceptible.

Tests of various combinations of electrical cords with coax cables show clear quality differences, particularly in relation to connectors.

Determining whether the standards were being met or not was, however, not the objective of these tests. Interference is still possible, even if these devices completely meet these requirements.

All measured values, mean and spread were required to feed the simulation model used to determine the probability of technical interference.

1. General Information

This section provides information about the various aspects that are applicable to all tests performed.

Choice of devices to be tested

6 television sets (TVs) were purchased and 6 set-top boxes (STBs) were borrowed from a cable company for the purpose of this test.

The TVs comprised 5 different brands. Two TV sets of the same brand were purchased, albeit from two separate series. The selected TVs have a 32" display diameter, are equipped with a DVB-C tuner and are suitable for displaying programmes broadcast by the Ziggo cable company using a Conditional Access Module with a Common Interface +.

The set-top boxes (STBs) comprise three brands. Two identical units, suitable for displaying programmes broadcast by the Ziggo cable company, were supplied for each brand. For comparison purposes, 3 old TVs with analogue TV reception were tested.

3 cable modems (CMs) were tested in the laboratory of a cable company.

No DVD or Blue Ray recorders were tested due to the fact that few devices with a DVB-C tuner are available on the market.

Appendix 1 contains the brand names, types and ages of the tested devices.

Test picture and evaluation criterion

The test picture is a recording of moving images. The recording is installed as a stream in a 5 minute loop in a signal generator with DVB-C modulation.

The image on the TV or monitor (with a set-top box) is evaluated in terms of the display of more than one block on the image.

Applied frequencies

A frequency, 834 MHz, in the future LTE band was used. For the out-of-band tests, the frequencies are identified in the table with the test results. 770 MHz was used as the frequency for the 'other channel' for the screening effectiveness tests.

Testing equipment

Where applicable, the testing equipment was calibrated using certified procedures at the time the tests were performed. Appendix 2 contains information about the testing devices.

2. Screening effectiveness of devices

This concerns the determination of the degree of HF screening provided by TV and STB tuners. This test is performed in the spirit of EN 55020 clause 5.5. This testing method assumes a device that is disconnected from a power source. In view of the fact that present-day tuners may exhibit different properties if they are connected to a power source, it was decided to perform this test on devices connected to a power source as well. The testing setup is described in Appendix 2. The usual term for this test is screening effectiveness.

The screening effectiveness of 6 new television sets, 6 new set-top boxes, 3 old TVs and 3 new modems was tested. In accordance with EN 55020, the screening must be at least 50 dB. The measurement tolerance is +/- 3 dB. The test results are displayed in Table 1.

No.	Brand/Type	Function	No power	Standby	Tuned channel	Other channel
1		TV	56 dB	59 dB	57 dB	65 dB
2		TV	79 dB	83 dB	73 dB	73 dB
3		TV	59 dB	58 dB	46 dB	46 dB
4		TV	59 dB	59 dB	55 dB	52 dB
5		TV	66 dB	66 dB	56 dB	64 dB
6		TV	62 dB	62 dB	57 dB	68 dB
7		STB	70 dB	60 dB	60 dB	55 dB
8		STB	74 dB	64 dB	64 dB	65 dB
9	Brand names	STB	48 dB	48 dB	45 dB	45 dB
10	are intentionally	STB	46 dB	52 dB	52 dB	51 dB
11	omitted	STB	58 dB	49 dB	51 dB	50 dB
12		STB	53 dB	44 dB	42 dB	46 dB
13		TV	60 dB	60 dB	58 dB	58 dB
14		TV	60 dB	60 dB	63 dB	60 dB
15		TV	70 dB	70 dB	66 dB	66 dB
16		CM	66 dB	Not available	66 dB	66 dB
17		CM	68 dB	Not available	68 dB	68 dB
18		CM	57 dB	Not available	57 dB	57 dB

Table 1. Screening effectiveness

Findings

Two devices, the STBs with sequence numbers 9 and 10, do not meet the EN 55020's requirements. There are major difference among tuners of the same type. Furthermore, there is a major difference among various tuners, depending on whether they are connected to a power source or not. The lowest screening effectiveness level measured is 43 dB, the highest is 79 dB. The screening effectiveness of modems is independent of whether they are connected to a power source or not. This is because a passive filter network has been installed immediately after the HF input.

3. Interference within and outside the band (input immunity)

The devices' coupling ratings and shielding requirements jointly determine the strength of the interference signal that will be generated within the cable networks. The individual devices should be immune to these. The level of robustness is determined using a test that supplies a wanted (digital TV) and unwanted (LTE) signal to a tuner. The unwanted signal is generated at the same frequency as the wanted signal; one channel higher and lower and five channels higher and lower. The ratio between a wanted and unwanted signal on the same frequency is sometimes referred to as the protection ratio. The usual term for this test is input immunity.

The test is performed in accordance with EN 55020 clause 5. The testing setup is described in Appendix 3.

The level of interference of 6 new TV sets and 6 new set-top boxes was tested. See Table 2.

The 3 cable modems were tested by establishing a telephone connection. Such a connection is more easily disrupted than an internet connection. A DVB-C transmitter (bandwidth of 6.875 MHz) was used to generate the interference signal.

The input immunity of the old TVs was not tested due to the lack of availability of an LTE generator at the time that the tests on these TVs were conducted.

All values in dB			1	2	3	4	5	6	7	8	9	10	11	12
			Brand names are intentionally omitted											
Channel	LTE (MHz)	up/downlink	tv						stb					
X	1.25	down	-11	-14	-16	-10	-6	-5	-15	-10	-13	-13	-11	-9
834 MHz	5	down	-20	-20	-21	-18	-18	-20	-19	-18	-20	-20	-19	-20
	10	down	-18	-22	-22	-18	-21	-20	-21	-23	-21	-21	-21	-20
	20	down	-20	-22	-21	-17	-24	-17	-21	-21	-22	-22	-23	-21
	1.25	up	-14	-12	-12	-18	-16	-11	-13	-14	-2	-12	-10	-10
	5	up	-22	-20	-24	-16	-20	-16	-21	-22	-17	-15	-17	-20
	10	up	-23	-23	-22	-17	-21	-14	-22	-22	-16	-16	-20	-20
	20	up	-23	-23	-22	-20	-23	-26	-22	-21	-16	-17	-20	-20
X+1	1.25	down	26	>30	>30	>30	>30	>30	>30	>30	>30	>30	>30	>30
842 MHz	5	down	21	>30	>30	>30	>30	>30	>30	>30	>30	28	>30	>30
	10	down	-4	-6	-4	9	-6	-6	0	0	8	8	0	-1
	20	down	-18	-19	-16	-13	-22	-21	-16	-13	-16	-16	-16	-16
	1.25	up	25	>30	>30	>30	>30	>30	>30	>30	>30	>30	>30	>30
	5	up	20	14	>30	>30	>30	>30	22	23	29	29	>30	>30
	10	up	16	14	25	>30	21	20	22	16	17	15	20	17
	20	up	-19	-20	-21	-24	-18	-12	-20	-18	-17	-17	-17	-20
X+5	1.25	down	>30	>30	>30	>30	>30	>30	>30	>30	>30	>30	>30	>30
874 MHz	5	down	>30	>30	>30	>30	>30	>30	>30	>30	>30	>30	>30	>30
	10	down	>30	>30	19	>30	>30	>30	>30	>30	>30	>30	12	10
	20	down	>30	>30	20	>30	>30	>30	>30	>30	>30	>30	14	10
	1.25	up	>30	>30	>30	>30	>30	>30	>30	>30	>30	>30	>30	>30
	5	up	>30	>30	>30	>30	>30	>30	>30	>30	>30	>30	>30	>30
	10	up	>30	>30	>30	>30	>30	>30	>30	>30	>30	>30	23	21
	20	up	>30	>30	19	>30	>30	>30	>30	>30	>30	>30	13	10
X-1	1.25	down	25	>30	>30	>30	>30	>30	>30	>30	>30	>30	>30	>30
826 MHz	5	down	20	>30	>30	>30	>30	>30	21	>30	21	21	>30	>30
	10	down	-6	-3	0	2	-4	-5	-1	-5	-7	-6	-3	-1
	20	down	-20	-17	-19	-17	-19	-17	-16	-12	-16	-15	-16	-17
	1.25	up	25	>30	>30	>30	>30	>30	>30	>30	>30	>30	>30	>30
	5	up	18	>30	>30	>30	>30	>30	28	26	26	26	>30	>30
	10	up	-6	-5	-4	2	-9	-3	-5	-5	-8	-12	-4	-3
	20	up	-6	-14	-17	-17	-18	-15	-13	-9	-14	-14	-11	-10
X-5	1.25	down	>30	>30	>30	>30	>30	>30	>30	>30	>30	>30	>30	>30
794 MHz	5	down	>30	>30	>30	>30	>30	>30	>30	>30	>30	>30	>30	>30
	10	down	>30	>30	>30	0	>30	>30	>30	>30	>30	>30	>30	>30
	20	down	>30	>30	>30	-14	>30	>30	>30	>30	>30	>30	>30	>30
	1.25	up	>30	>30	>30	>30	>30	>30	>30	>30	>30	>30	>30	>30
	5	up	>30	>30	>30	>30	>30	>30	>30	>30	>30	>30	>30	>30
	10	up	>30	>30	>30	>30	>30	>30	>30	>30	>30	>30	>30	>30
	20	up	>30	>30	>30	>30	>30	>30	>30	>30	>30	>30	>30	>30

Table 2. Interference within the band and outside the band

Findings

The smaller the bandwidth of the LTE signal, the larger the probability of interference to the in-band signals. Furthermore, there is a difference between uplink (SC-FDMA) and downlink (OFDMA) LTE modulation. In addition, there is a difference in the in-band interference level of tuners in the presence of small-band signals.

In terms of the measurements outside the band, it is naturally primarily evident that in case of one channel higher and lower, the broadband-type LTE signals produce a poor protection ratio.

According to EN 55020, the wanted signal at the tuner should be 60 dBµV. This is higher than the signal provided by the cable. At the Customer Connection Point (CCP), the required level is namely 55 dBµV.

Cable modems reproduce good signals until the level of interference drops 26 dB below the wanted signal. That level is comparable to the level attained by the poorest TVs.

4. Direct radiation (radiated immunity)

Devices must be immune to a certain level of external HF fields. In accordance with the EN 50020, TVs must be immune to a field strength of 106 dB μ V/m at the frequency to which the device is tuned (in-band immunity). The 106 dB μ V/m level corresponds to 0.2 V/m. The tests were conducted in a GTEM facility. The testing setup is described in Appendix 4.

The tests were conducted on 6 new TV sets and 6 new set-top boxes. The results are displayed in Table 3.

The tolerance of the measured values for this test is +/- 6 dB.

For testing the radiated immunity of the cable modems, a DVB-C generator with a signal level of 20 dBm (approximately 2 V/m) was available, while an LTE generator was not available. The test was conducted in the cable modem laboratory of a cable company. The three modems tested (and all 47 other modems in the same area) continued to perform well in the presence of this field strength.

All values in V/m			AM				LTE downlink bandwidth (MHz)				LTE uplink bandwidth (MHz)				
No.	Brand/Type	Function	80%	1,25	5	10	20	1,25	5	10	20	1,25	5	10	20
1		TV	1,5	0,2	0,2	0,2	0,2	0,2	0,2	0,2	0,2	0,2	0,2	0,2	0,3
2		TV	>3	>3	>3	>3	>3	>3	>3	>3	>3	>3	>3	>3	>3
3		TV	>3	1,5	1,3	1,4	2,1	1,9	1,3	>4	1,7				
4		TV	1,2	0,8	0,4	0,9	1,3	0,9	0,8	>5	1,2				
5		TV	2,1	1,6	1,2	1,5	1	1,2	1,2	>6	2				
6	Brand names	TV	>3	1,2	0,7	0,6	1	1,5	0,7	>7	1,3				
7	are intentionally	STB	>3	>3	>3	>3	>3	>3	>3	>8	>3				
8	omitted	STB	>3	>3	>3	>3	>3	>3	>3	>9	>3				
9		STB	1,1	1	0,9	1,8	1,7	1,1	1	>10	1,6				
10		STB	1,9	0,6	0,6	0,6	1,5	0,9	0,9	>11	1,5				
11		STB	1,2	1,2	0,9	0,9	1,2	0,6	0,6	>12	0,7				
12		STB	>3	1,3	1,1	1,3	1,9	2,3	0,8	>13	2				

Table 3. Radiated immunity

Findings

If the 6 dB tolerance is ignored, all devices meet the 0.2 V/m requirement. If the tolerance is applied, however, the limit is between 1.25 and 0.4 V/m. If the standard testing method is applied, all devices are compliant. One TV (number 1) drops out with the LTE signals.



Laboratory for testing cable modems

5. Implications for in-home networks

This component was completed after the three activities described above were finished. The knowledge produced by these activities was used to conduct the in-home network measurements.

The screening effectiveness test results provided cause for investigating this for an ordinary in-home network. A two-way distributor was used to install two coax cables from the CCP to two adjacent rooms.

The TV in one room was replaced by a spectrum analyser. Two TVs and an STB were connected in turn in the other room. A 23 dBm LTE signal was generated in that same room. The influence on a connection (spectrum analyser) was then measured in the other room. Table 4 displays the corresponding results. The testing setup is described in Appendix 6. The attenuation between the outputs of the two-way distributor used was 30 dB.

No.	Brand/Type	Function	No power	Standby	Tuned channel	Other channel
2	Brand names	TV	0 dB	2 dB	1 dB	4 dB
4	are intentionally	TV	2 dB	4 dB	2 dB	4 dB
10	omitted	STB	3 dB	3 dB	2 dB	3 dB

Table 4. Influence of screening effectiveness among devices

Findings

A small influence was perceptible. This influence however has no clear relationship with the measured major variances in the screening effectiveness of the TVs and STBs used. Furthermore, the attenuation of a distributor is of such magnitude that the influence expected due to this phenomenon is minor.

6. Direct radiation for various cable compositions

The quantity of energy from a transmitter that ends up in the cabling was measured for various cable compositions.

A transmission signal with an ERP of 23 dBm was generated at a distance of 1 to 3 metres from a cable. The length of the cable was 5 metres. The cables were of different quality. The

same applied to the plugs mounted at either side of the cable. The cable was connected on one side to a TV or an STB. A spectrum analyser was connected to the other side of the cable. The results are displayed in Table 5. The cables and plugs used are shown in Table 6. The testing setup is displayed in Appendix 5, Figure 7.

Nr.		TV no. 2		TV no. 3		TV no. 15		STB no. 10	
		1 m	3 m	1 m	3 m	1 m	3 m	1 m	3 m
A	Kabelkeur	-70	-72	-71	-72	-71	-70	-70	-68
B	KEMA-keur	-72	-72	-72	-73	-71	-70	-70	-68
C	Hirschmann	-72	-70	-71	-71	-72	-71	-70	-68
D	5 mm F	-72	-72	-72	-72	-72	-71	-71	-68
E	7 mm F	-71	-71	-71	-72	-71	-71	-71	-68
F	5 mm plastic	-54	-48	-44	-49	-54	-44	-50	-52
G	Gamma profi	-53	-58	-59	-62	-62	-58	-57	-54
Living room with wooden floor									
Nr		TV no. 2		TV no. 3		TV no. 15		STB no. 10	
		1 m	3 m	1 m	3 m	1 m	3 m	1 m	3 m
A	Kabelkeur	-70	-73	-72	-71	-72	-72	-72	-72
B	KEMA-keur	-73	-73	-72	-72	-72	-72	-72	-52
C	Hirschmann	-73	-73	-70	-70	-72	-72	-72	-70
D	5 mm F	-71	-71	-71	-70	-72	-72	-72	-52
E	7 mm F	-72	-73	-71	-72	-72	-72	-72	-72
F	5 mm plastic	-50	-54	-49	-51	-43	-47	-47	-70
G	Gamma profi	-62	-59	-50	-58	-50	-55	-50	-72
Living room with concrete floor									
Nr		TV no.2		TV no. 3		TV no. 15		STB no. 10	
		1 m	3 m	1 m	3 m	1 m	3 m	1 m	3 m
A	Kabelkeur	-68	-68	-64	-64	-60	-60	-53	-53
B	KEMA-keur	-68	-68	-64	-64	-60	-60	-53	-53
C	Hirschmann	-68	-68	-64	-64	-60	-60	-53	-53
D	5 mm F	-68	-68	-64	-64	-60	-60	-53	-53
E	7 mm F	-68	-68	-64	-64	-60	-60	-53	-53
F	5 mm plastic	-31	-31	-30	-30	-31	-31	-33	-33
G	Gamma profi	-37	-37	-33	-33	-40	-40	-38	-38
Office									
All numbers in dBm									
Frequency 834 MHz									

Table 5. Direct radiation for various cable compositions

No.	Description	Coax Cable	Connectors
A	Already assembled	Kabel Keur	IEC type fixed
B	Already assembled	KEMA keur	IEC type fixed
C	Homemade	Hirschmann KOKA 799	Hirschmann KOSW13 + KOKW13
D	Homemade	5 mm	F type
E	Homemade	7 mm Kabel Keur	F type
F	Homemade	5 mm	IEC type plastic housing
G	Homemade	RG6U	IEC type metal coated housing

Table 6. Cables and plugs used



Findings

There is only a small difference between the test results of a Kabel Keur, KEMA-KEUR and best homemade cable. This is why these values were made identical. The quality of the coax cable and plugs combination is almost entirely determined by the type of plug.

Appendix 1 Testing Equipment

Function	Brand	Type	Serial number
Signal Generator	Agilent	E4428C	MY45280624
Signal Generator	R&S	SMBV100A	255002
Broadcast Test System	R&S	SFU	101713
Power Amplifier	Bonn	BSA 0104	76701
E-Field Sensor	Radi Sense	CTR 1001A	06D00036SNO-66
Spectrum Analyzer	R&S	ETL	101231
Spectrum Analyzer	R&S	FSP	100817
TV signal measuring receiver	KWS Electronics	AMA300	36270
GTEM	ETS-Lindgren	5411	77257
Logger Antenna	EMCO	3148	1243

Appendix 2 Setup for Testing Screening Effectiveness of Devices

The screening effectiveness testing setup was structured in accordance with EN 55020. See Figure 1. The generator produces an unmodulated carrier wave at 834 MHz. For testing a non-tuned-in channel a 770 MHz carrier wave was generated. The HF output of the STBs is closed off with a 75 ohm resistor.

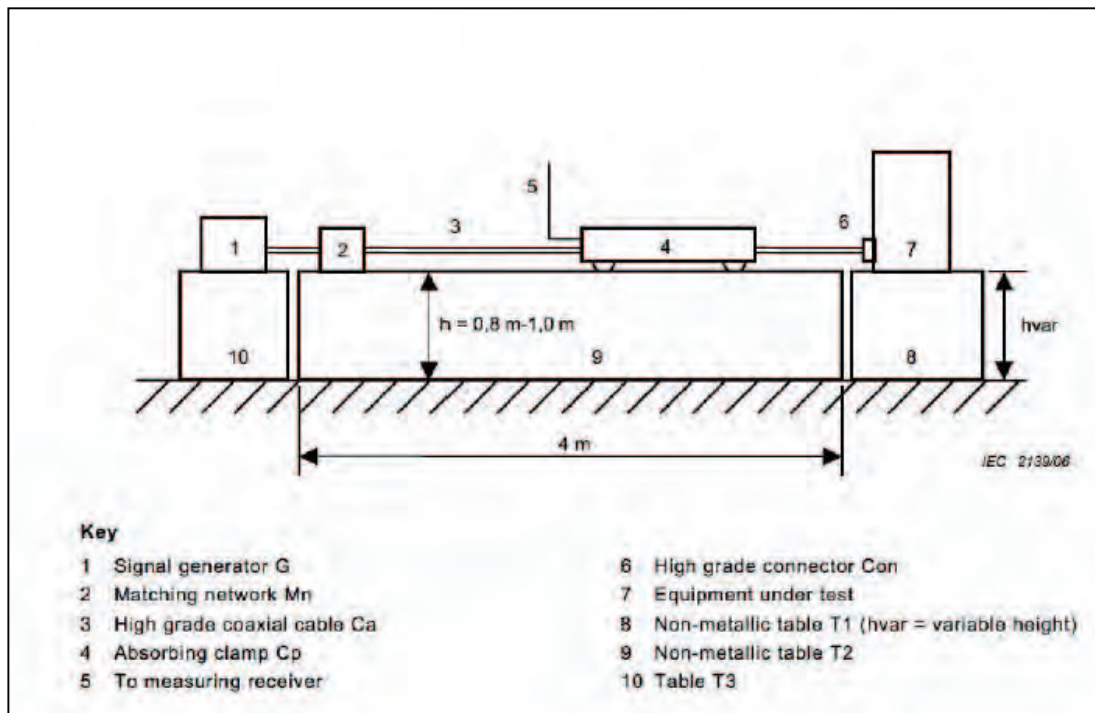

Figure 1. Setup for testing screening effectiveness

Appendix 3 Setup for Testing Input Immunity

The testing setup was structured in accordance with EN 55020. See Figure 2. The wanted signal was DVB-C at 834 MHz. The input level of this signal at the tuner was 60 dBμV as indicated in EN 55020. The unwanted signal was LTE in 4 bandwidths (1.25 , 5 , 10 , 20 MHz). These bandwidths were generated in uplink and downlink mode.

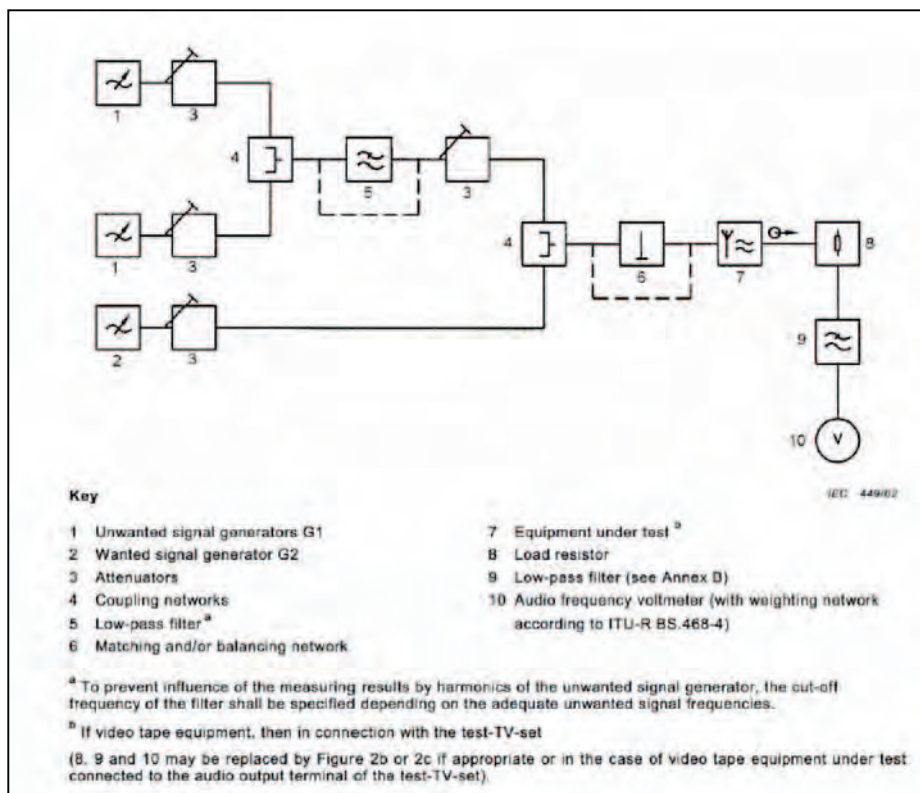

Figure 2. Setup for testing input immunity

Appendix 4 Setup for Testing Direct Radiation

The testing setup consisted of a generator, amplifier and transmission antenna. See Figure 3. The transmission antenna was mounted in an HF tight room in which the device to be tested was placed. The generated field was measured with a sensor. See Figures 4 and 5.



Figure 3. Setup for testing immunity; GTEM (Gigahertz Transverse Electromagnetic Cell)



Figure 4 and 5. Sensor near set-top box and television set in GTEM

Appendix 5 Setup for Testing In-home Networks and Cables

The testing setup consisted of two cable television connections that were connected to the CCP via a two-way distributor. The TV 'to be tested' was replaced by a spectrum analyser. The second connection consisted of a TV or an STB. A generator with a transmission antenna infused the coax cable connected to the TV or STB.

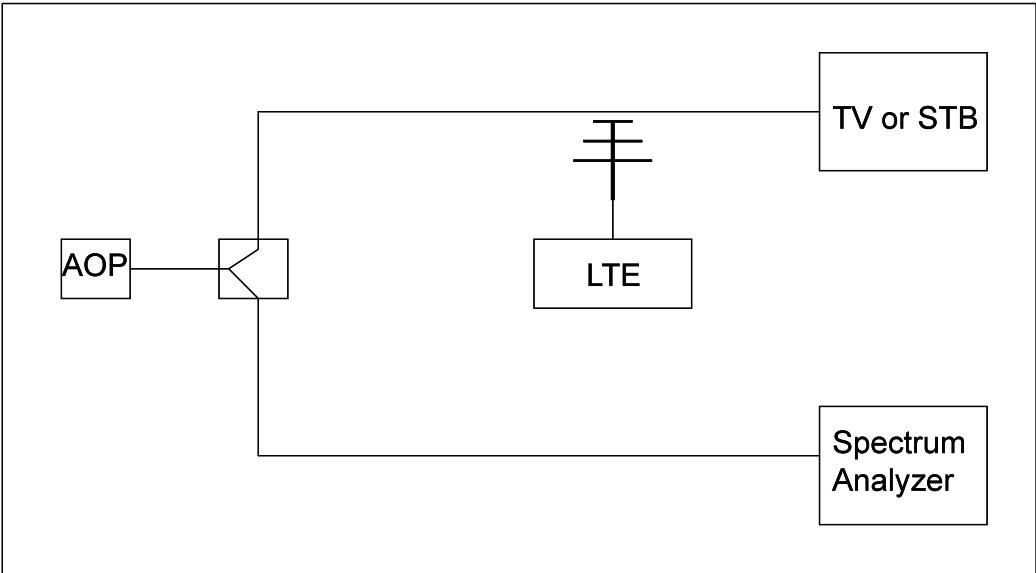

Figure 6. Setup for testing mutual influence among TVs and STBs

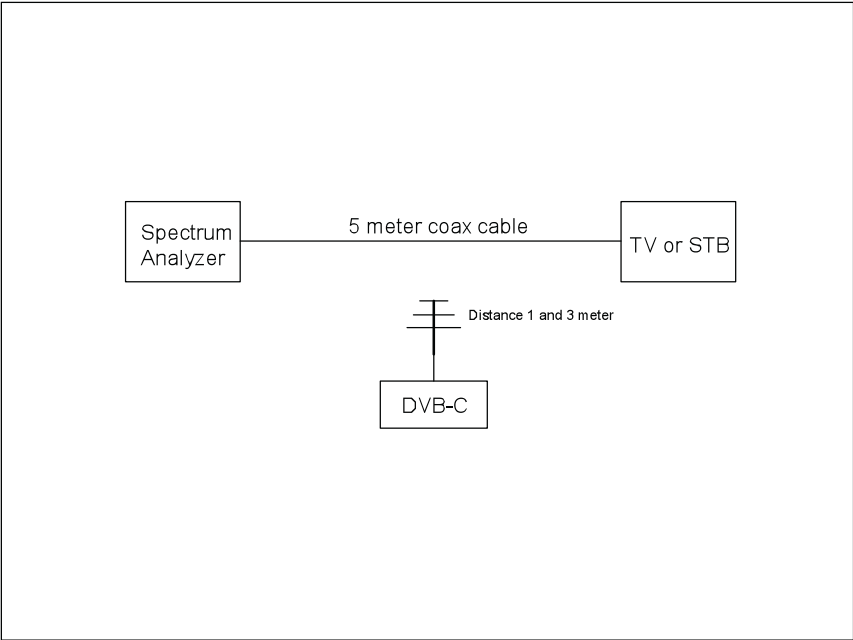

Figure 7. Setup for testing cables and plugs

Annex 7: LTE parameters

Radiocommunications Agency Netherlands

For the purpose of the tests conducted by the Radiocommunications Agency NL, an SMBV100A Rhode & Schwarz Vector Signal Generator was used to generate an LTE signal. The settings of this generator were as follows:

Channel Bandwidth	1.25 MHz	5 MHz	10 MHz	20 MHz
Number of Resource blocks per slot	6	25	50	100
FFT Size	128	512	1024	2048
Number of occupied subcarriers	73	301	601	1201
Number of left guard subcarriers	28	106	212	424
Number of right guard subcarriers	27	105	211	423

Uplink: SC-FDMA

Downlink: OFDMA

General settings: QPSK, FDD Mode

This configuration for the most part corresponds to the standard system parameters of the 3GPP E-UTRA specifications, such as 3GPP TS 36.101 V9.3.0 (2010-03) ('Technical Specification Group Radio Access Network; Evolved Universal Terrestrial Radio Access (E-UTRA); User Equipment (UE) radio transmission and reception').

25 dBm was assumed as the maximum power of an LTE. This is consistent with the 800 MHz Decision of the European Commission: 'Commission Decision 2010/627/EU on harmonised technical conditions of use in the 790-862 MHz frequency band for terrestrial systems capable of providing electronic communications services in the European Union'.

A footnote in this Decision indicates that the power of a 23 dBm LTE mobile is subject to a tolerance. "It is recognised that this value (of 23 dBm) is subject to a tolerance of up to +2 dB, to take account of operation under extreme environmental conditions and production spread."

It was assumed that the LTE in the 800 MHz frequency band makes use of an FDD system. This means that the uplink and downlink frequency bands are separated, in contrast to a TDD system, whereby the uplink and downlink are within the same frequency band. The FDD frequencies in the 800 MHz band were as follows: FDD uplink in the 832-862 MHz frequency range and FDD downlink in the 791-821 MHz frequency range.

This corresponds to the band subdivision prescribed in the 800 MHz Decision of the European Commission.

Annex 8: Evaluation of external research

Radiocommunications Agency Netherlands

A number of existing research efforts was compared. The table below summarises the relevance of this research. The key differences are inherent in the assumptions made.

Table. Relevance of existing research

Ranging from little relevance to high relevance in five steps (--, -, 0, +, ++).

Comments (see [] in the table) are added following the table.

Item	NLkabel (Anga/IRT)	1 st rapport NL (Indication)	BAKOM	BnetZA	2 nd rapport NL (Draft)	Cable Europe	
Behaviour of LTE terminal	++	0 [1]	++ [2]	+ [3]	++ [4]	0 [1]	
The wanted signal							
- DVB-C		++ [8]	++ dBuV >= 55 (EN 50083-7)	+	+	+	
- Analogue PAL		++ [8]	++ dBuV >= 55	+	+	+	
- EuroDOCSIS				+	+	+	
Immunity of device				++	++	++	
CCP – Device connection	++			--	++	+	
Configuration issues	++						
- Other connections		+					

(HDMI)									
Leakage to neighbours	++	+	--	++ [5]	--	++ (Expected)	--		
Application of static model (probability of interference)		0			--	++	--		
Similarities									
- Device properties									
- LTE behaviour									
- Cabling requirements		++ [10]	++ [6]			++ [10]			
- DVB-C	+	+	+		++ [7]	+	+		
- PAL	+	+	+		++ [7]	+	+		
- ROUTER	+	+	+		+	+	+		
- CATV net	--	--	--		--	? [9] [10]	--		

Comments

1. LTE mobile transmits at maximum allowable capacity of 25 dBm.
2. For the time being, the BAKOM report (Workshop 25/1 Slide 4) offers a practical approach (on the basis of an IMT rural cell).
3. Description: LTE in idle mode as well as with uplink active (also note the details in terms of the transmission's bandwidth).
4. It is desirable (in accordance with the objective of Workshop 25/1) to compare the assumptions currently used with those of the BAKOM report.
5. BAKOM presentation, Slide 10: Calculation of probability of interference on the basis of the 'busy hour' principle.
6. Good cable > 60 dB, poor cable 28 dB. BAKOM assumed the EN 50083-2 standard (85 dB) up to inside the device.

7. Documented with rationale in an appendix. The result is striking: probability of immunity to interference for PAL and DVB-C is equal, but the subject here specifically deals with direct radiation. BnetZA considers DVB-C 256QAM as well as DVB-C 64QAM (with a compensated difference of 6 dB).
8. Measured as part of the random sample: signal level of CCP and at the input of the TV?!
9. All research initiatives assume: cable net (HFC) with a mix: analogue, DVB-C, EuroDOCSIS. The signal levels are briefly mentioned, but not the spreads, nor the assumptions in relation to the "home's environment". Because the following applies: stronger signal (PAL, DVB-C, modem), less (chance of) interference the material provided is not sufficient to form a good picture.
10. Clarity must be created in terms of the (diversity of the) construction of in-home networks. This is data that could be important for all researchers (comparison of the immunity of receivers). The University of Twente observed the current configurations in their research (see Annex 2).

Annex 9:

Cable networks - background

Radiocommunications Agency Netherlands

Cable networks channel allocation

Four different signals are in principle transported in a downstream direction in a cable network. These are:

- Analogue radio in the FM band
- Analogue TV
- Digital TV via DVB-C
- Digital services, via DOCSIS, including internet and telephony

The broadcasting bands IV and V are primarily used to distribute analogue and digital TV channels. A digital channel with an 8 MHz bandwidth is capable of transporting 6 - 8 TV channels, depending on the quality.

Digital channels are received with the help of a DVB-C receiver. Most TVs do not have such a receiver, which is why a set-top box is usually used. To extract the different TV signals from the various DVB-C channels on the cable network, the set-top box uses a homing channel. This means that the consumer does not have to look up the channels himself. This also means that if the cable company decides to allocate its digital TV channels to the DVB-C channels on the cable in a different way, this does not in principle affect its customers. This is different for analogue TV channels. If these are reallocated within the cable network, this means that all customers must adjust their TV sets accordingly. This is a relatively major one-time operation for a cable company, because all customers must be notified about this and where necessary provided with assistance.

Because different types of signals are distributed on the cable network as indicated earlier, most cable networks are currently pretty well saturated. This means that expansion, for example of digital TV channels is almost virtually impossible without affecting the number of analogue TV channels or the available internet capacity on the cable network. Emptying a portion of the cable spectrum, because it is subject to interference for the most part means that the offer of service will have to be constrained, or that investments (sometimes of a drastic nature) will have to be made to limit the impact¹.

Most cable networks have approximately 70 - 75 downstream channels of 8 MHz each available. Analogue and digital TV are almost exclusively distributed on broadcasting bands III, IV and V. The frequency room between band III and band IV is used for DOCSIS channels, although these can also be allocated to the broadcasting bands. A cable network has between 30 and 35 analogue TV channels and assuming 150 digital TV channels, approximately 25 DVB-C channels. The remaining 10 to 15 channels are used for DOCSIS.

Signal level

The signal level of TV channels at the Customer Connection Point must be between 60 and 77 dB μ V. The signal may not go too high, to avoid overdriving the TV receiver. Calculated from the terminal repeater, each home connection has its own unique distance to that repeater. This means that the frequency-dependent cable attenuation between the terminal repeater and the customer connection point differs for each home. The tap at the terminal repeater, to which the in-home cables are connected, compensates as much as possible for this difference. However, some variances will continue to exist. As a result it is possible that households with a high signal as well as a low signal may be connected beyond a terminal repeater. The consequence of this is that the signal level of the terminal repeater cannot be set higher

¹ For example, by further segmenting the network, it is possible to provide the same internet capacity with fewer DOCSIS channels.

without any limitations, without causing problems for customers. A higher signal level on the cable network furthermore causes the non-linearity of repeaters and lasers to increase, which in turn creates more inter-modulation problems². Increasing the signal of a few channels by, for example, 5 dB is probably feasible.

² Repeaters in the cable network currently operate at the limit of their linear operating range. Increasing the signal by more than a few dBs can result in highly non-linear behaviour.

Annex 10: Related aspects

Radiocommunications Agency Netherlands

There are a number of trends that could also affect the probability of interference to cable TV caused by the new LTE mobiles. These were not included in this research.

LTE base station

An LTE base station located at a distance of 50 metres from a home and that transmits at 1 kW EIRP, could in theory cause the same level of interference to TV reception as a mobile telephone at a distance of 3 metres within the living room. In view of the relatively small number of homes that are located within 50 m of a base station, this interference effect has been left out of consideration in the statistical calculations.

Nevertheless, the Radiocommunications Agency NL tested a number of GSM and UMTS base stations. The signal generally stays below 2 V/m in the neighbourhood of homes. This is in part compelled by the Netherlands EMC directive, that rules against the network operator in case of complaints received from nearby residents in case of signal strengths experienced by the closest home that are higher than 5.4 V/m. This is inclusive of an assumed modulation.

Abroad, where such a rule does not apply, the power measured for LTE base stations is much higher than it is for GSM and UMTS. Calculations performed on the basis of these higher levels of power, produce a larger radius around the base stations within which interference can occur.

UTP

A new trend is the use of unshielded twisted pair (UTP), a cheaper cable material than coax, specified up to 400 MHz, that is increasingly more often rolled out behind the Customer Connection Point in large complexes and is used to pass on the entire band up to 860 MHz. This falls under the responsibility of the building operator. No research has yet been performed in this area, but the probabilities of interference are expected to increase.

Cable modems

Cable modems can also operate in the Digital Dividend band. The cable distribution companies could avoid this band, but they are confronted with a full spectrum. It is expected that the cable modems and set-top boxes will be integrated over the coming years. The signals are already the same at a physical level. In terms of susceptibility to interference, the cable modem would then no longer perform a specific function. At that time the only distinction would be the different software's signal recovery capacity. The tuner in a cable modem is entirely comparable to that in a TV or STB. Research conducted by the Radiocommunications Telecoms NL and the Ziggo cable company shows that the findings related to TVs also apply to modems.

HDMI

HDMI is a digital cable connection between different types of equipment, including the TV and the set-top box. HDMI assumes the functionality of the analogue SCART connector at this location. Unlike the SCART connector, longer cables are also supplied for HDMI. It is possible that this causes immunity to deteriorate. In view of the fact that there are 2 categories of software and firmware, and TVs often have several HDMI connections, it is not possible to specifically identify their effect on immunity. Further research could potentially demonstrate this effect on deteriorating immunity.

Indeed, other (foreign) investigations have shown that LTE signals can also cause interference to HDMI cables (digital video/audio cable) between the digital tuner and the TV. HDMI is a digital cable connection between different types of equipment, including the TV and the Set-top Box. HDMI assumes the functionality of the analogue SCART connector at this location. Unlike the SCART connector, longer cables are also supplied for HDMI. It is possible that this indeed causes immunity to deteriorate. To ascertain the impact of this more precisely would require further research.

Annex 11:

LTE interference to DVB-T

Radiocommunications Agency Netherlands

No research was conducted into the interference of LTE to DVB-T in preparing this report. It is however possible to identify a number of highlights derived from research carried out in a European context in 2009 (namely in ECC PT SE42).

- First, a condition for the use of the 790-862 MHz band for mobile communication applications is that DVB-T must be removed from that band. LTE applications, base stations, as well as mobile telephones, would otherwise experience unacceptable interference from DVB-T transmitters. Assuming that the 470-790 MHz frequency band is used for DVB-T, the research into compatibility between LTE and DVB-T demonstrates the following:
- LTE base stations and LTE mobile telephones, if these were allowed in the 790-862 MHz band, could cause interference to DVB-T (as well as DVB-H) in the 470-790 MHz band.

LTE base stations

Without any supplementary measures, this would create gaps in the DVB-T service, particularly channel 60 (782-790 MHz). These gaps could be a few hundred metres in size, depending on the power. So-called 'mitigation techniques' are required to resolve this interference. Examples include the co-siting of base stations and DVB-T transmitters, decreasing the power of the base station, increasing the power of DVB-T transmitters, adjusting the antenna height, pattern and direction, etc. This problem peaks on DVB-T channel 60. The problem is less serious at lower DVB-T channels, but not negligible. Interference to DVB-T caused by base stations is more serious with roof antenna reception than with in-home reception. As is known, the rollout of DVB-T in the Netherlands is based on in-home reception.

The operators (DVB-T operator and LTE operator) have control over the resolution of interference to DVB-T by base stations: they are in a position to make mutual arrangements to take measures designed to largely prevent interference to DVB-T by base stations (the fact that they have control over this does not mean, however, that this is something that is always easy to solve). This requires policy choices to be made about the way in which this is documented as part of the licence conditions.

LTE mobile telephones

The current DVB-T receivers are not very immune to interference by mobile telephones in the 790-862 MHz band. The distance at which current DVB-T receivers can experience interference from a mobile telephone can be greater than 10 metres.

To lessen this sensitivity requires modification to DVB-T receivers: for example, the use of an external filter or new DVB-T receivers in which signals above 790 MHz are filtered out (whereby any large-signal behaviour of the active antenna must also be taken into account). According to the calculations, after taking these measures, the interference distance between the mobile telephone and the DVB-T receiver is limited to between 0 and at most 3 metres, depending on where you are located in the DVB-T service area. Furthermore, a 3 metre interference distance is an exceptional case. In most situations, the interference distance will be smaller than 1 metre. In the then remaining cases of interference, the only realistic solution is to increase the distance between the mobile

telephone and the DVB-T receiver, for example by moving the mobile telephone away from proximity to the DVB-T receiver.

In general, the operators (DVB-T and mobile) do not have control over the interference to DVB-T caused by mobile telephones. If it occurs, there are barely any realistic options for the operators to do something about this. The end-users must do that themselves by increasing the distance between the mobile telephone and the DVB-T receiver.

This problem is not limited to DVB-T channel 60 (782-790 MHz), but also occurs in lower DVB-T channels. Interference to DVB-T caused by mobile telephones is more serious with in-home reception than with roof antenna reception.

Annex 12: Glossary

CCP:	Customer Connection Point. The connection point between the fixed cable and the viewer-consumer's own in-home coax cabling to be installed by him/her.
Base station:	The radio station with which a mobile device communicates.
EuroDOCSIS:	The modulation system used for the traffic with a personal PC via a modem.
HDMI:	High Definition Multimedia Interface: digital audio and video cables and plugs that can be sensitive to interference from the direct radiation of 800 MHz signals.
LTE:	Long term Evolution. The 4 th generation devices and successor to UMTS.
STB:	Set-top Box. A device that can be used with a TV and that contains a digital tuner and a decryption unit.
UMTS:	Universal Mobile Telecommunications System, 3 rd generation mobile telephone.

Annex 13:

Bibliography

3GPP TS 36.101

3GPP TS 36.101; 3rd Generation Partnership Project; Technical Specification Group Radio Access network; Evolved Universal Terrestrial Radio Access (E-UTRA); User Equipment (UE) radio transmission and reception (Release 8)

Radiocommunications Agency Netherlands

Study of Interference to Digital Cable TV Caused by 800 MHz Mobile LTE Applications; Report on 1st and 2nd Sets of Tests, Report for DGET, Groningen, 27 November 2009.

BAKOM

EC workshop, *cable TV receivers affected by new radio services in the 800 MHz band*, (René Tschannen), Brussels, 25 January 2010.

BnetzA

Measurement Report G531/01077/09, *Immunity of Integrated TV Receivers, Set Top Boxes and Data Modems Connected to Broadband Cable and TV Networks against Radiation from LTE User Equipment*, (Thomas Hasenpusch, FNA), 28 January 2010.

ECC

Questionnaire on Cable TV receivers affected by New Radio services in the 800 MHz Digital Dividend band, Working group RA, RA1 on Enforcement, Helsinki, 26 March 2010.

Copsey for Cable Europe

Implications of the Digital Dividend Proposals; Cable Europe Labs Testing Program; Part 8, Part 2 Plan: Set Top Boxes (STB); Part 6 Plan: Cable Modems (CM); Part 7; CELDD02 V1.0 , 11th February 2009.

http://ec.europa.eu/information_society/policy/ecomm/radio_spectrum/_document_storage/studies/misc/cable_europe_study800mhz.pdf

European Commission

Commission Decision 2010/627/EU on harmonised technical conditions of use in the 790-862 MHz frequency band for terrestrial systems capable of providing electronic communications services in the European Union

EN 55020

EN 55020:2007; Sound and television broadcast receivers and associated equipment - Immunity characteristics - Limits and methods of measurement (CISPR 20:2006)

EN 50083-2

EN 50083-2:2006; Cable networks for television signals, sound signals and interactive services -- Part 2: Electromagnetic compatibility for equipment

EN 50083-7

EN 50083-7:1996; Cable networks for television signals, sound signals and interactive services -- Part 7: System performance

IRT / ANGA

Beeinflussung der Dienste auf TV-Kabel-Infrastrukturen durch bidirektionale terrestrische Anwendungen LTE (Long Term Evolution) im UHF-Bereich, Berlin and Munich, April 2009.

ITU

ITU document 5-6 / 131-E : 2009-11-12 by the Radio Communication Study Groups and Philips International: TV RECEIVER MANUFACTURER'S MEASUREMENTS OF LEGACY, CURRENT AND FUTURE DVB-T RECEIVER PERFORMANCE UNDER INTERFERENCE FROM DVB-T IN NEARBY CHANNELS

Philips

Philips Applied Technologies Ref: EMC-09-KB-009-RRP, Radiated Immunity Tests of a TV Set to Assess the EMI Risk of CATV-Connected Equipment.



ISBN 978 908 15 7322 1